

The influence of floor materials in room fires

Patrik Johansson, Jesper Axelsson and Tommy Hertzberg

SP Technical Research Institute of Sweden



Brandforsk project 300-061

The influence of floor materials in room fires

Patrik Johansson, Jesper Axelsson and Tommy Hertzberg

Brandforsk project 300-061

Abstract

The influence of floor materials in room fires

An enclosure flashover will involve all combustible materials in the room, also the flooring material. Recently, it has been shown that the choice of flooring material actually might aggravate an already severe fire scenario. This project focus on investigating the influence of flooring material for creating a flashover and the possibility for the existing European classification system to provide relevant fire classes for enclosure flooring materials.

Key words: flame spread, floor coverings, cone calorimeter, full scale tests, heat release rate, smoke production rate

SP Sveriges Tekniska Forskningsinstitut
SP Technical Research Institute of Sweden

SP Report 2007:29
ISBN 978-91-85533-89-3
ISSN 0284-5172
Borås 2007

Contents

Abstract	3
Contents	4
Preface	5
Summary	6
1 Background	7
1.1 Fire testing methods	8
1.2 European test method for flooring materials	9
1.3 Implications for fire safety	11
2 Project set-up	12
2.1 Materials used	12
2.2 Experimental methods	12
2.2.1 Radiant Flooring Panel test, EN ISO 9239-1	13
2.2.2 Cone calorimeter test, ISO 5660	13
2.2.3 Large scale fires based on ISO 9705, Room/Corner	15
3 Experimental results	18
3.1 EN ISO 9239-1	18
3.1.1 Smoke in EN ISO 9239-1	20
3.2 ISO 5660 Cone calorimeter	20
3.2.1 Smoke in ISO 5660 Cone calorimeter	22
3.3 Large scale tests	23
3.3.1 Scenario 1 tests	23
3.3.2 Scenario 2-3	25
3.3.3 Scenario 3'	27
3.3.4 Scenario 4	28
3.3.5 Smoke from large scale experiments	32
4 Discussion	34
5 Conclusions	36

Preface

It has previously been shown that the flooring material might have a significant impact on fire incidents in relation to flashover situations. Tragic examples were the Växjö 2003 hospital fire and the Gothenburg discotheque fire of 1998.

This aim of the reported project was to try to understand what impact a particular choice of material would have on flashover fires and to investigate if the existing European classification method for flooring materials was sufficient for a correct ranking of materials with regards to its influence on enclosure fires.

The Swedish Board for Fire Research (Brandforsk) sponsored this project with reference number 300-061 which is gratefully acknowledged.

Acknowledgment is given to the staff of SP Fire Technology involved in this project. Special thanks to Magnus Samuelsson, Lars Pettersson, Hans Börjesson, Sven-Ove Vendel, Patrick van Hees and Björn Sundström.

Summary

In this project two small scale test methods, the EN ISO 9239-1 standard used for European classification of flooring materials and the ISO 5660 Cone Calorimeter test method, were used to rank five different flooring materials with regards to their fire behaviour. Furthermore, large scale tests were made in the ISO 9705 Room-Corner enclosure using four different scenarios. Three of these scenarios were based on the ISO 9705 gas burner and heat release rate curve (10 min 100 kW, 10 min 300 kW) with steel plates mounted above the burner, thus providing a heavy radiation towards the flooring material. In the fourth scenario a heptane pool fire was used to initiate flashover fires in the enclosure.

It was found in the project that the flooring material that obtained the highest ranking in the EN ISO 9239-1 test method of the tested materials, a PVC flooring material (B_{FL} -class), obtained the lowest ranking in the flashover test. Other materials used in the project were a C_{FL} -class rubber floor covering and D_{FL} -class materials (particle board, polypropylene and linoleum floor coverings).

The EN ISO 9239-1 test method is solely based on flame spread characteristics and the PVC floor covering will not ignite if the radiation level is below 9 kW/m^2 , which is 2-3 times as high as for the rest of the tested materials. If, however, the radiation is higher than 9 kW/m^2 , the PVC floor covering will ignite quickly and the flame spread will be faster than for any other material used in this study. Therefore, the shortest time to flashover in the heptane scenario was obtained when the PVC floor covering was used in the experiment. The material also provided the highest amount of smoke.

1 Background

In two different Swedish fire disasters, the Gothenburg discotheque fire in 1997 and the Växjö hospital fire in 2003, the flooring material has been proven to have had a major impact on the outcome and severity of the fire incident^{1, 2, 3, 4}.

In the Gothenburg discothèque fire, a linoleum floor covering on wood was a main reason for fire propagation from a flashover fire in the escape stairway where the fire was initiated, into the discothèque, where 63 young people were killed by the smoke and fire.

In Växjö, the rescue personnel entered into the fire building fast but had difficulties finding their way due to very heavy smoke. A reconstruction of the fire demonstrated that a too easily ignitable mattress provided heat enough to ignite a PVC flooring material that then became the main fire and smoke source. In the reconstruction, the HCl-concentration in the fire smoke was approximately equal to the CO-content and analysis of soot from the fire site showed up to 10 % by weight of chlorine, proving that the PVC floor covering did indeed contribute heavily to the overall hospital fire. This also provided an explanation to the very heavy smoke reported. Two young patients were killed in this fire.

Both accidents demonstrates that the choice of flooring material can have a large impact on the enclosure fire (fire size and dynamics) and the amount of smoke produced and its toxicity. It is clear that a non-combustible floor covering would have prevented both incidents from having such tragic consequences.

However, the influence of flooring materials in a fully developed room fire is not very well known or documented. Thus its potential danger might be underestimated and neglected in many cases. For instance is the legislative requirement for surface linings (on ceilings and walls) in public spaces more severe than for flooring material in the same spaces. The reason for this negligence is probably that the main focus has been to prevent a flashover situation and studies that report on impact of flooring material are therefore mainly considering fire initiation and growth⁵. You might even find statements in scientific literature saying that flooring material not should to be “considered a serious threat” in a fire situation⁶.

Some previous studies have already shown the risk of floor covering in room corridors set-ups and the lack of correlation with existing legislative methods both for room corridor scenarios, room scenarios and staircases^{7 8 9 10}. This report studies the importance of different flooring material in a flashover situation and investigates if the existing small scale Euroclass testing method for flooring materials can be used to map large scale quality ranking.

1.1 Fire testing methods

Fire testing is usually very pragmatic in the sense that testing methods try to map a possible real life fire scenario into a well-controlled technical apparatus for measuring potential fire hazards in a certain material or product. The fire characteristics determined in fire tests then decide where and when a material might be used, depending on legislation and fire safety considerations.

Over time, a consensus regarding critical physical parameters to be measured in fire tests has evolved, these are summarised in Table 1. Whether only a limited number of these parameters or if all of them need to be evaluated depends on the application of the material.

Table 1 Characteristic and testable fire parameters.

No	Physical fire characteristics of a material or product
1	Ignitability
2	Speed of flame spread
3	Heat release rate (HRR)
4	Total Energy content (THR)
5	Smoke production rate
6	Smoke toxicity
7	Structural resistance to fire

These parameters are measured in different ways depending on the imitated fire risk scenario and with various criteria depending on the hazards involved. Generally speaking, the greater the hazards and the more people and/or economic values that are at risk, the more severe the test and the criteria for passing the test will be. The fire characteristics map different stages of a fire. Point number 1 and 2 in Table 1 focus on the fire initiation and growth, “ignition phase”, as depicted in Figure 1, whereas number 3-7 includes all phases. The characteristics in Table 1 are not all completely independent of one another. But they are not completely dependent either.

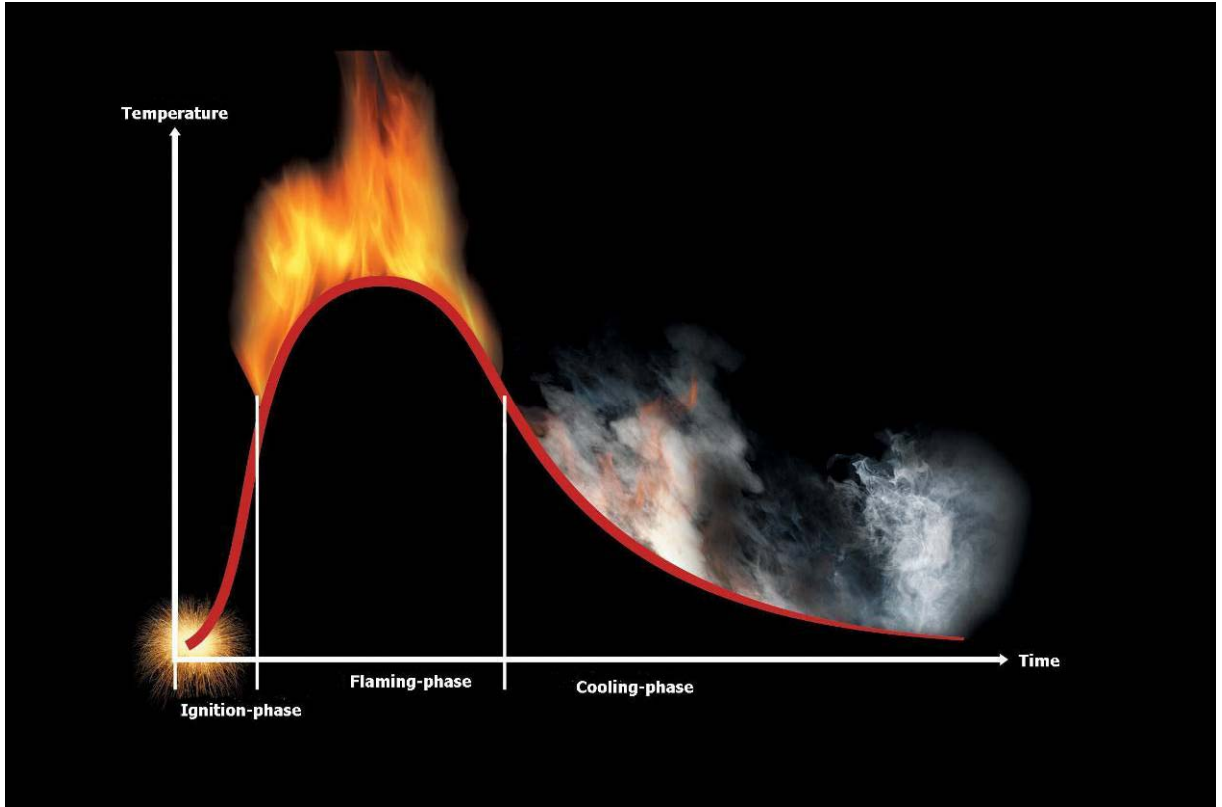

Figure 1 Schematic picture of fire dynamics.

1.2 European test method for flooring materials

Flooring materials are ranked in EN 13501-1 after tests according to EN ISO 9239-1 as¹ A_{2FL}, B_{FL}, C_{FL} or D_{FL} ("FL" is a flooring material tag) The length of flame spread on the material is measured in EN ISO 9239-1 tests in the apparatus shown in Figure 2. A_{2FL} is the highest level of classification and D_{FL} materials will burn approximately twice the length of B_{FL} classed materials. The test focus on fire initiation and growth as indicated in the following quote from EN ISO 9239-1.

"The measurements in this test method provide a basis for estimating one aspect of fire exposure behaviour of floorings. The imposed radiant flux simulates the thermal radiation levels likely to impinge on the floor of a corridor whose upper surfaces are heated by flames or hot gases or both, during the early stages of a developing fire in an adjacent room or compartment under wind-opposed flame spread conditions."

No consideration of calorific value is made except for class A_{2FL}, Heat Release Rate is not considered at all. In addition, the smoke production is not considered as an important material quality. A smoke classification is included, i.e. class s1 and s2, but the limits for the highest level s1 is so generously defined that many materials will have the s1 class.

¹ An A_{1fl} class also exists but the classification is based on calorific content, EN ISO 1716, and non-combustibility, EN ISO 1182, of the material. For the A_{2fl} class the classification is based both on the flame spread characteristics and on calorific content.

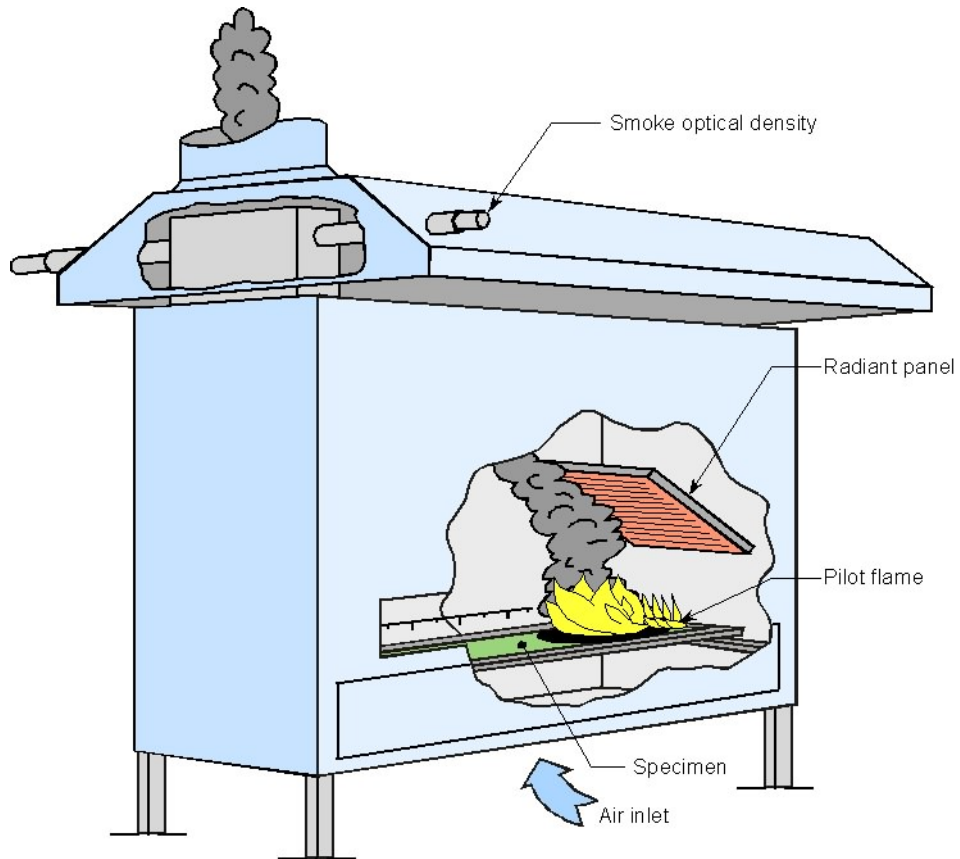

Figure 2 Test equipment for flooring materials according to standard EN ISO 9239-1.

1.3 Implications for fire safety

When investigating the total calorific values in a public space it can be found that flooring materials often provides a significant or even dominant part of total available energy in a fire, e.g. in corridors or other areas with few upholstered furniture. It is known from the Gothenburg fire that this was the case for the discotheque enclosure and that combustible flooring material was the main reason for the fire spread into this area.

A floor covering usually provides several tens of MJ/m² of energy to be released in a fire and when an enclosure fire has attained a flashover situation, the possibility of fire spread to adjacent spaces depends on the duration of the fire which of course depends on available combustible materials. Also, the main cause of death from a fire is intoxication by fire smoke and the amount of smoke gases produced depends on durability and intensity of the fire but also on what type of materials that are burning. If a fully developed fire would have been a major concern when fire safety with relations to flooring material was discussed, then perhaps more severe restrictions would have been used for other fire characteristics than flame spread.

Floor coverings can have a very important influence on the amount of energy and smoke produced as demonstrated in the Växjö hospital fire in 2003. A mattress was the probable main cause for a flashover in a small ~10 m² enclosure. The mattress contained approximately 100 MJ of energy but the PVC floor covering in the same room contained 2-3 time as much energy, probably even more as it is likely that there were old floor coverings still left underneath the top one. The fire was very intense but lasted only 15 minutes after which there was virtually no trace left of the floor covering. It was reported by the fire fighters that the smoke was so dense that it made rescue of patients very difficult and it was found that the main reason for this heavy smoke was the floor covering^{1,2}.

The European classification system based on tests according to EN ISO 9239-1 does not consider material qualities important for a flashover or a fully developed fire, the focus of the classification system is corridors and escape routes. There is a risk that choice of flooring materials will be made of people unaware of these underlying motivations for classification. ISO 9239-1 has recently been developed to investigate higher heat flux levels closer to the levels created in a flashover situation after a request from Japan. This resulted in ISO 9239-2 which deals with flame spread at the heat flux level of 25 kW/m² compared to the European methods level of around 12 kW/m².

2 Project set-up

The basic idea for the project was to investigate the behaviour and influence of flooring material close to flash-over in a room and to study if the ranking of materials according to EN 13501-1 correlate with the behaviour in larger fires. The latter were performed in a somewhat modified ISO 9705 Room/Corner fire scenario. In addition, small scale Cone calorimeter tests were performed according to ISO 5660. The reason for this was to include other small scale material characteristics, i.e. time to ignition, Heat Release Rate (HRR), Total Heat Released (THR), smoke, (characteristics 1, 3, 4 and 5 in Table 1) than those provided by EN ISO 9239-1 (flame spread and smoke, characteristics 2 and 5).

2.1 Materials used

Five different materials were chosen for the project as listed in Table 2. The types of materials were chosen so that well-known and often used material groups were represented and also materials that comprised a significant variation in classification according to the standard EN ISO 9239-1. However, the particular choice of material within each group is entirely random.

Table 2 Materials used in the investigation.

Material	Surface weight (kg/m ²)	Thickness (mm)
PVC-floor covering	2.8	2.0
Polypropylene floor covering	1.57	8.5
A linoleum floor covering	3.0	2.5
Particle board	12.3	19
Rubber floor covering	3.6	2.2 - 3.0

2.2 Experimental methods

Two small scale experimental methods were used in the project, the radiation panel based test method defined by EN ISO 9239-1 and the Cone Calorimeter method ISO 5660. The large scale fires were run in a modified ISO 9705 Room-Corner fire scenario.

2.2.1 Radiant Flooring Panel test, EN ISO 9239-1

The specimens are loosely put on a non-combustible board with a nominal thickness of 6 mm. Duration of the test is 30 minutes. The test specimen is placed in a horizontal position below a gas-fired radiant panel inclined at 30° where it is exposed to a defined heat flux (see Figure 2²). The sample tested is thus submitted to a thermal energy gradient and the heat flow is 11 kW/m² at 110 mm from the hotter end of the specimen and 1.1 kW/m² 910 mm away from this end. A pilot flame is also applied to the hotter end. Following ignition, any flame front which develops is noted and a record is made of the progression of the flame front horizontally along the length of the specimen in terms of the time it takes to spread to defined distances. Smoke production is measured continuously by means of white light system, with a lamp on one side of the exhaust duct and a detector on the other side. The integrated smoke value, calculated as the integral of the smoke obscuration over the testing time and expressed in % *x time*, is used for the additional smoke classification. Principle of the test method is also described above in 1.2.

2.2.2 Cone calorimeter test, ISO 5660

A well-known small-scale experimental method is the ISO 5660¹¹ Cone Calorimeter (Figure 3) test where a 0.01 m² specimen, horizontally positioned, is subjected to irradiation from electrically heated surfaces above the tested material. Irradiation levels are typically in the range of 25-50 kW/m². This test equipment is used mainly for measuring ignitability, HRR (Heat Release Rate) and THR (Total Heat Release) for a given material, i.e. it is used for measuring parameters 1, 3 and 4 in Table 1. Several models and simulation tools use data from the Cone calorimeter to simulate larger fires.

As

Figure 3 shows, the standard Cone Calorimeter test also includes measuring smoke and some gas concentrations. HRR is calculated based on the amount of oxygen consumed by the fire. Figure 4 shows the HRR curve for such an experiment. As can be seen, the fire dynamics depicted can be described by the general fire behaviour shown in Figure 1, i.e. by an ignition phase, a flaming phase and a cooling phase. The maximum HRR, however, is a function of heat- and mass flow from/to the sample and depends not on available oxygen as in a flashover.

The total heat release (THR) is obtained through integration of the HRR over time. THR is a very important characteristic for a burning material as it shows the tendency to sustain and add energy to a fire.

² The classification system also includes an ignition test according to EN-ISO 11925-2 but this is normally not critical for the classification obtained.

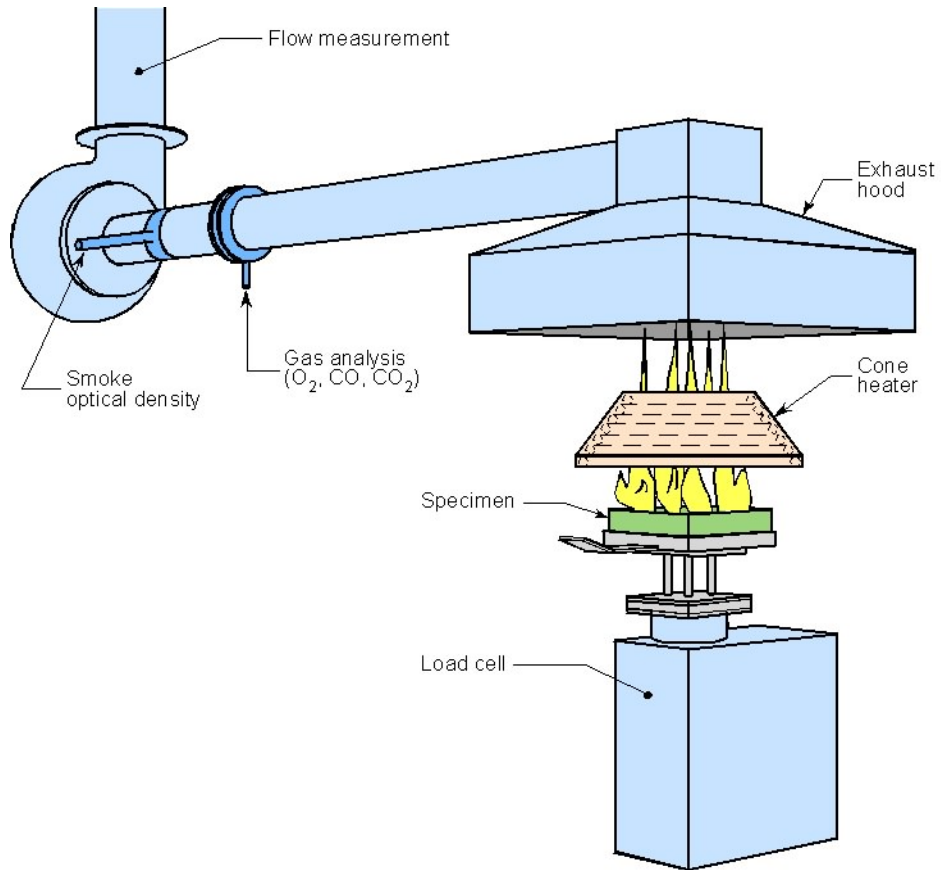

Figure 3 Schematic picture of a Cone Calorimeter.

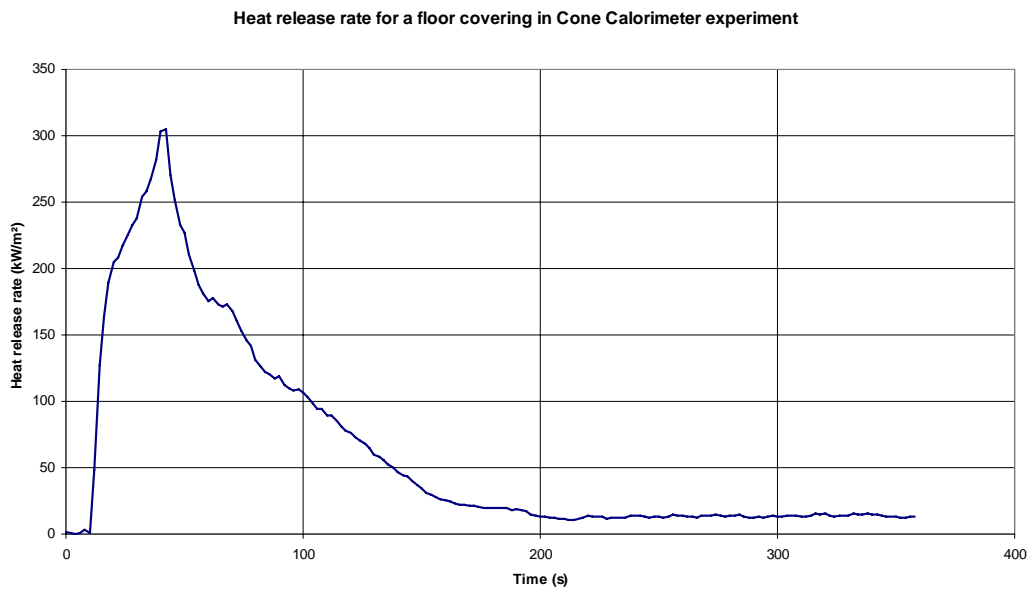

Figure 4 Small-scale experimental results from a floor covering.

2.2.3 Large scale fires based on ISO 9705, Room/Corner

An important and well-known large scale experimental set-up is the ISO 9705 Room-Corner test scenario¹², schematically pictured in Figure 5. In this test, a propane gas burner positioned in a corner of a full-scale room provides a 100 kW power output for 10 minutes, followed by 300 kW output for an additional 10 minute period. The HRR and smoke production rate are continuously measured. This test is the reference scenario for surface linings. The ISO 9705 test is also very important for marine applications as it is the base for testing of fire restricting materials used in HCS's (High Speed Crafts).

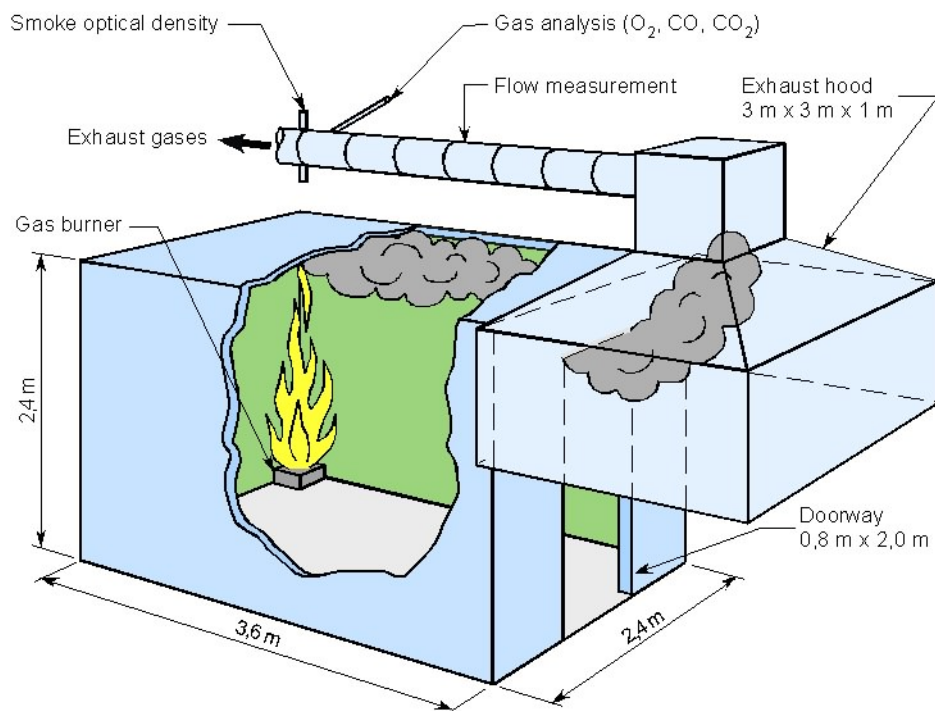

Figure 5 Schematic view of ISO 9705 Room-Corner experimental set-up.

In this project five different fire scenarios have been used based on the ISO 9705 room: **Scenario 1:** an ISO 9705 test (i.e. using 100+300 kW gas burner for 10+10 minutes) using a steel “table”, a 1.0 x 1.0 m steel plate positioned in the inner right corner above the burner, 0.40 m above the floor (0.25 m above the burner surface). Both PVC and particle board floor coverings were tested in this scenario.

Scenario 2: the same as 1 but burner + table positioned along a centre-line from the middle of the doorway opening towards the back of the room, with the centre of the burner and table at 0.90 m from the doorway. Only the PVC floor covering was tested in this scenario.

Scenario 3: The same as 1 but gas burner + table positioned in the right corner closest to the doorway instead of the standard position shown in Figure 5. Only the PVC floor covering was tested in this scenario.

Scenario 3’: The same as 3 but instead of the table, a “bed” consisting of a 0.9 x 2.0 m steel plate was used above the burner. Two experiments were run in this scenario; one using a PVC floor covering and another using a polypropylene floor covering.

Scenario 4: a circular fire tray (height=0.15 m, diameter=0.62 m) was filled with 10 cm (30 l) of water and 4 cm (12 l) of heptane. The tray was positioned 0.3 m above the floor in the standard ISO 9705 burner position, i.e. in the inner right corner, and burning heptane was used as a fire source instead of the gas burner. Four different flooring materials were tested in scenario 4, PVC, particle board, linoleum and polypropylene floor covering.

Photos of the 4 scenarios are shown in Figure 6.



Figure 6 Room/Corner test set-up/experiment in the 4 different project scenarios. Top row: scenario 1 and 2. Bottom row scenario 3 and 4.

The reason for using a steel plate (scenario 1, 2, 3 and 3') was to increase the thermal radiation towards the floor. It was found in the reconstruction of the Växjö hospital fire² that the bed mattress ignited the flooring material underneath the mattress by burning particles and droplets and together caused an intense flashover. The idea in the project was to see if radiation in itself was enough, i.e. a fire without any dripping mattress (PUR) material to create a pool fire on the floor underneath the bed. Tests were made with and without a small pilot ignition flame situated at the floor, close to the burner.

The main idea about scenario 4, the heptane pool fire, was to study the influence of flooring materials as a real flashover situation was approached. A gas burner could have been used for producing sufficient amount of energy but a heptane pool fire produces a heavy smoke layer that made the experiment more realistic by providing a high level of radiation towards the floor.

In most of the tests a plate thermometer was used. The plate thermometer has a large exposed surface to make it more sensitive to radiation than a standard thermocouple. The surface of the thermometer was faced upwards to receive the same temperature as the surface of the floor covering. As seen in section 3.3.4 the plate thermometer can be used to give information regarding the radiation received at the surface of the specimen, which can be interesting when comparing the results with the other test methods used in this project. The plate thermometer was placed under the “table” or “bed” in some of the scenario 1-3 tests. Two plate thermometers were used in all scenario 4 tests. One was placed close to the heptane tray, 0.9 meter from the rear wall and 0.9 meter from the right wall. The other was placed in the middle of the room, i.e. 1.8 meter from the rear wall and 1.2 meter from the long walls.

3 Experimental results

All five materials were run both according to EN ISO 9239-1 and ISO 5660. Four of them was tested in the large scale test.

3.1 EN ISO 9239-1

A summary of the results from testing the materials according to EN ISO 9239-1 is given in Table 3. The left column of the table gives the heat flux at the maximum flame spread point, e.g. the radiation for PVC floor covering at 225 mm (maximum flame spread and point of extinction) from the hotter end is 9.0 kW/m². As can be seen from Table 3, the PVC floor covering is “outstanding” with regards to flame spread quality and is the single material in the project that pass as B_{FL}-class floor covering.

The limits for the different Euroclasses shown in Table 3 are described in the classification standard EN 13501-1. To achieve Euroclass B_{FL} the flame spread shall stop before the heat flux is below 8.0 kW/m², which is equal to a flame spread of approximately 270 mm from the hotter end. The limit for Euroclass C_{FL} is a heat flux of 4.5 kW/m², equal to 450 mm, and the limit for Euroclass D_{FL} is a heat flux of 3.0 kW/m², equal to 560 mm. The smoke class is either s1 or s2. The class is based on total smoke produced during the test and the limit between the classis is 750 % x min, a value of absorption of light integrated over test time.

Table 3 Summary of EN ISO 9239-1 test results for the flooring materials used in the project (mean value given for 2 consecutive tests).

	Heat flux at 30 min, kW/m ²	Maximum flame spread, mm	Light absorption, % x min	Euroclass*, EN 13501-1
PVC	9.0	225	190	B _{FL} -s1
Rubber	4.8	435	416	C _{FL} -s1
Linoleum	4.3	470	208	D _{FL} -s1
Particle board	4.0	490	31	D _{FL} -s1
Polypropylene	3.3	540	117	D _{FL} -s1

*Indicative Euroclass since no full test series is performed and no tests according to EN ISO 11925-2 are performed

Table 3 lists the results that are the basis for classification according to EN ISO 9239-1. Length of flame spread versus time was also measured in the tests and reported according to standard. The results from these measurements are shown in Figure 7 and further evaluated in

Figure 8. A somewhat surprising finding is that the B-classed material, PVC floor covering, actually provides the fastest flame spread until the critical flame spread heat flux is attained at 225 mm from the hotter end of the sample.

Table 4 shows the ranking of materials based on calculated initial speed of flame spread.

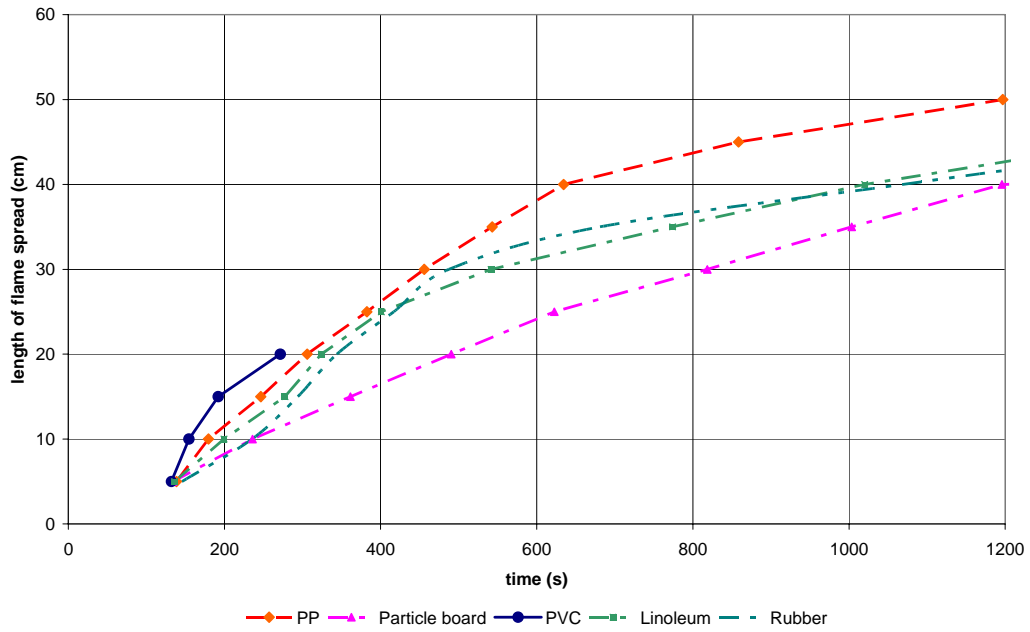

Figure 7 Measured flame length of flame spread as a function of time.

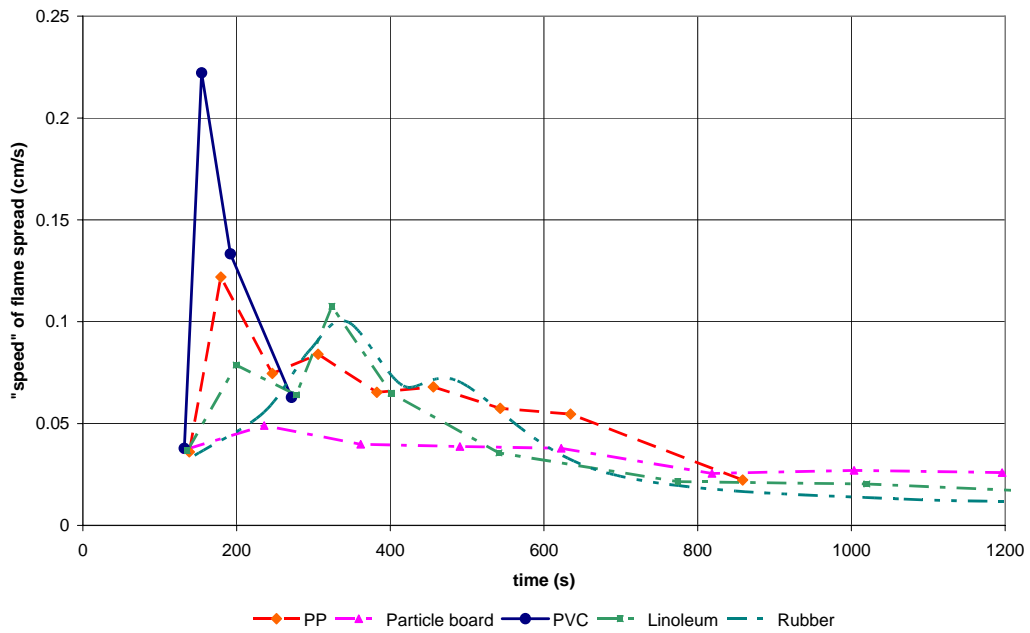

Figure 8 "Speed" of flame spread, calculated as $(\Delta x/\Delta t)$ based on length (x) and time (t) as given by Figure 7.

Table 4 Ranking based on calculated mean values for flame spread over the first 15 cm of tested sample .

Rank	Material	Average initial flame spread (cm/s)
1	Particle board	0.042
2	Rubber	0.058
3	Linoleum	0.060
4	Polypropylene	0.078
5	PVC	0.13

3.1.1 Smoke in EN ISO 9239-1

The PVC material produces the highest amount of smoke initially until the flame spread stops at the 9 kW/m² level, as shown in Figure 9.

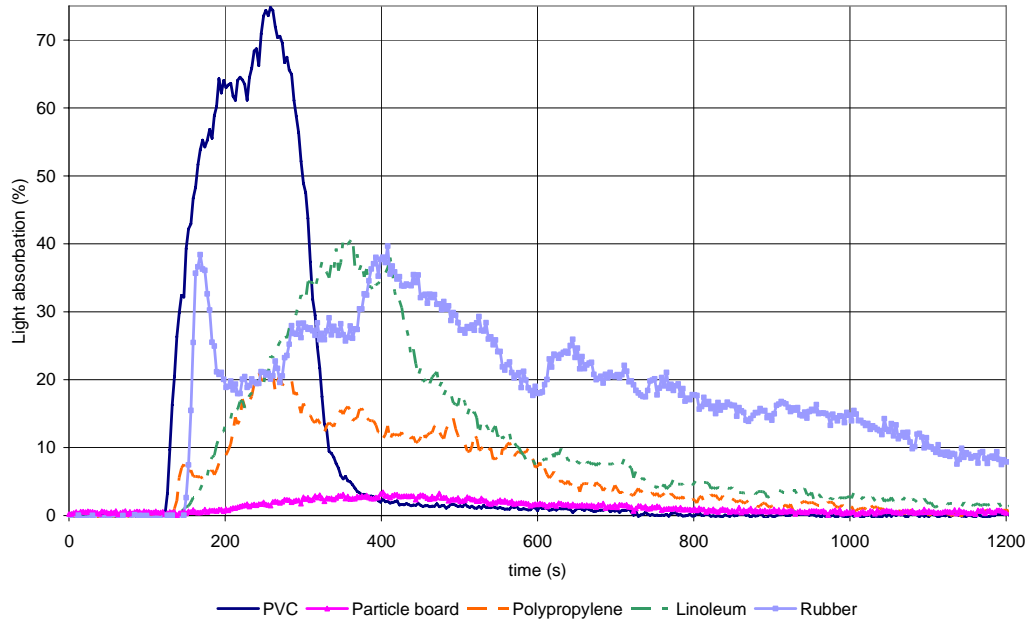

Figure 9 Smoke production from the EN ISO 9239-1 test method.

3.2 ISO 5660 Cone calorimeter

The tests performed in the Cone calorimeter provides quite a different ranking of materials compared to EN ISO 9239-1. A summary of results are given in Table 5 where the ranking has been made based on ignition times. It can also be seen that the smoke values (Peak SPR and TSP) provides a very different ranking compared to EN ISO 9239-1 and Table 3. This can probably be explained by the fact that in the Cone calorimeter, the whole surface area is involved and burns for all materials whereas in the radiation panel test, only parts of the sample surfaces are burning. The total effect curves (HRR) are shown in Figure 10.

Table 5 Summary of test results from ISO 5660 Cone calorimeter tests of the flooring materials at a heat flux level of 50 kW/m²

	Ignition time, seconds	Peak HRR, kW/m ²	THR, MJ/m ²	Peak SPR, m ² /m ² s	TSP, m ² /m ²
Particle board	27	247	121.7	2.2	295
Linoleum	27	400	53.6	9.7	710
Rubber	23	754	47.7	24.1	871
PVC	14	302	22.3	30.6	1410
Polypropylene	12	582	36.7	11.2	387

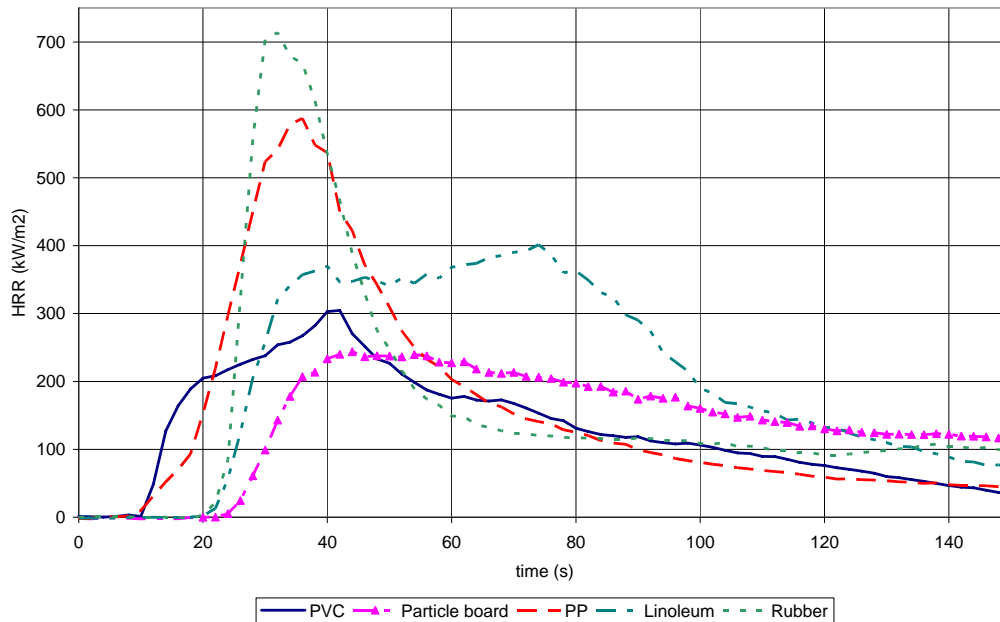

Figure 10 HRR for the different flooring materials in the Cone calorimeter test at 50 kW/m² heat flux level.

The tests in the Cone calorimeter were run at 50 kW/m², i.e. the heat flux level was substantially higher compared to the EN ISO 9239-1 test. Therefore, a number of Cone calorimeter tests were performed using a decreasing level of heat flux level to see if there would be a difference between the B_{FL}-class and a D_{FL}-class material at lower radiation levels. The results from these tests are shown in Table 6. As can be seen, the PVC material used ignites quicker even at 15 kW/m² radiation level. The results are actually very much in accordance with the findings shown in Figure 7 and

Figure 8, i.e. the rate of ignition/flame spread for the (by EN ISO 9239-1) B_{FL}-rated material, is faster than for D_{FL}-rated material.

Table 6 Ignition time comparison for Euroclass B material (PVC floor covering) and Euroclass D material (particle board).

Cone calorimeter heat flux level (kW/m ²)	PVC: Ignition time, seconds	Particle board: ignition time seconds
50	14	27
40	20	42
20	114	179
15	210	354

3.2.1 Smoke in ISO 5660 Cone calorimeter

The results from the smoke measurements in the Cone calorimeter tests are shown in Figure 11. The B_{FL}-classified PVC floor covering used in the investigation provides substantially more smoke than any other material tested. This is more clearly seen in Figure 12 from graphs showing the total smoke production.

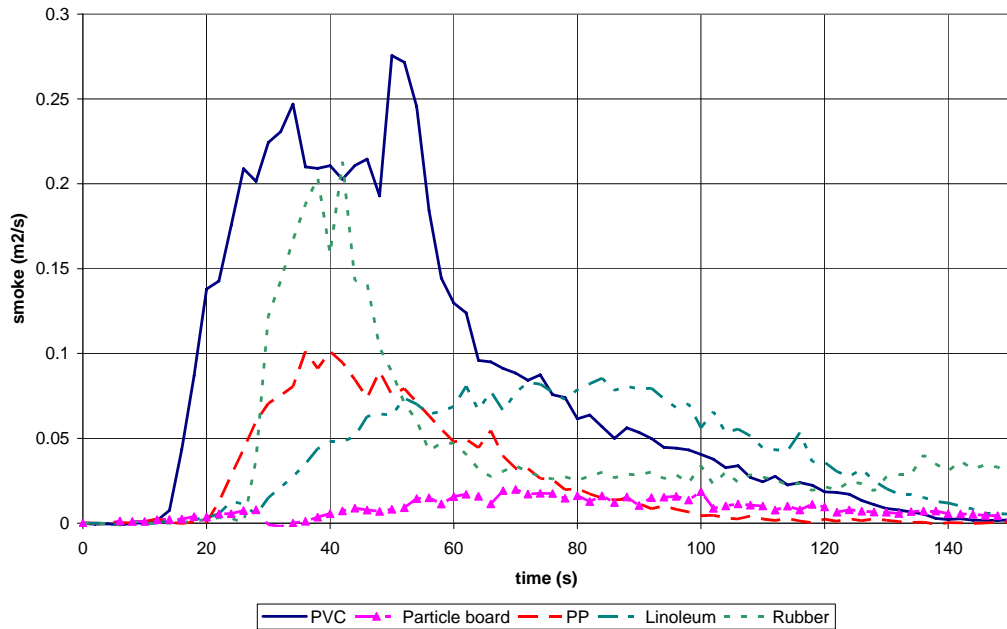

Figure 11 Smoke production rate in the ISO 5660 Cone calorimeter experiment .

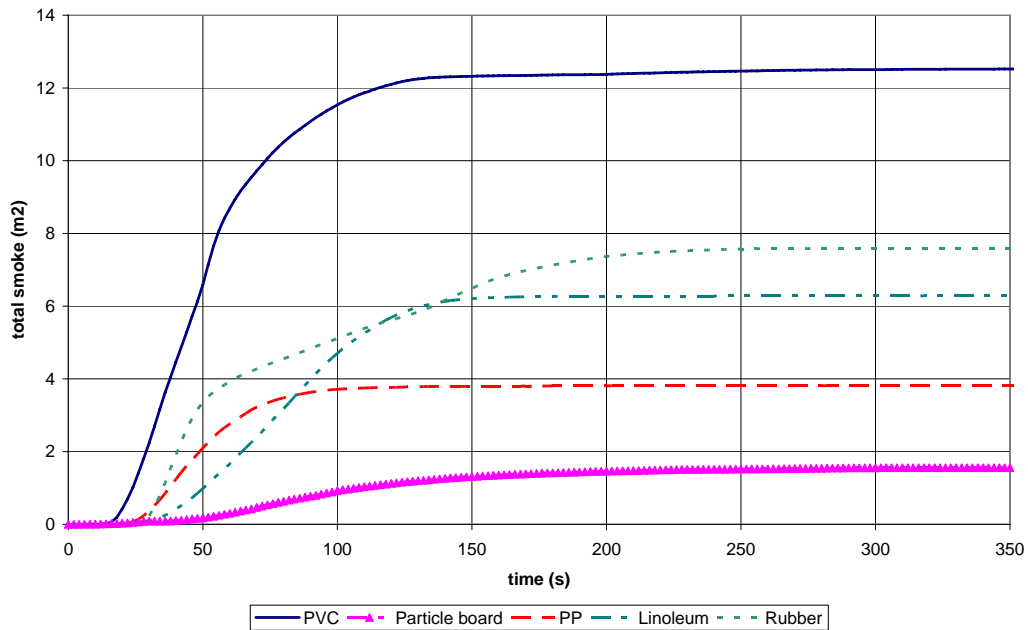

Figure 12 Total smoke production for the floor covering materials tested in ISO 5660.

3.3 Large scale tests

As described previously, five different large scale scenarios were tested, all based on the ISO 9705 Room-Corner test scenario.

3.3.1 Scenario 1 tests

In scenario 1, a steel table was mounted in the inner right corner of the Room-Corner enclosure above the burner. The gas burner placed in the right corner produced 100 kW for 10 minutes and then 300 kW for another 10 minutes. Tests were made both with and without a pilot burner situated at the floor close to the burner. In Figure 13 the HRR-results from two experiments are shown where PVC floor coverings were used.

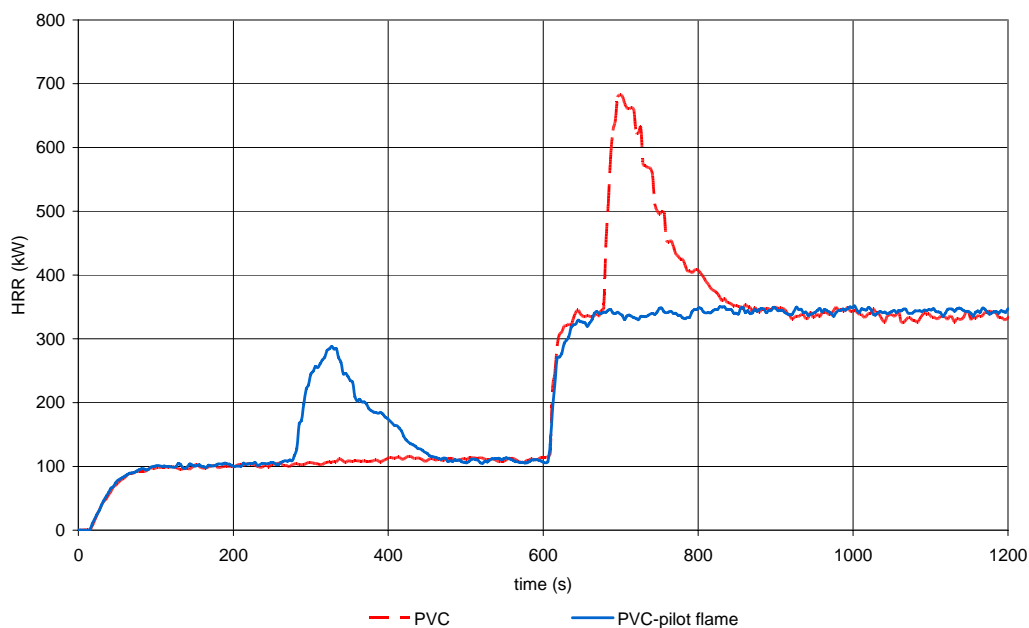

Figure 13 Scenario 1 tests with and without a pilot burner. Gas burner HRR is included.

As can be seen from the above test, the pilot flame makes a significant difference in fire behaviour for the floor covering. Without the flame, ignition of the floor takes longer time. A general conclusion from the large scale tests was that it was better to use the pilot flame instead of spontaneous ignition as reproducibility gets better.

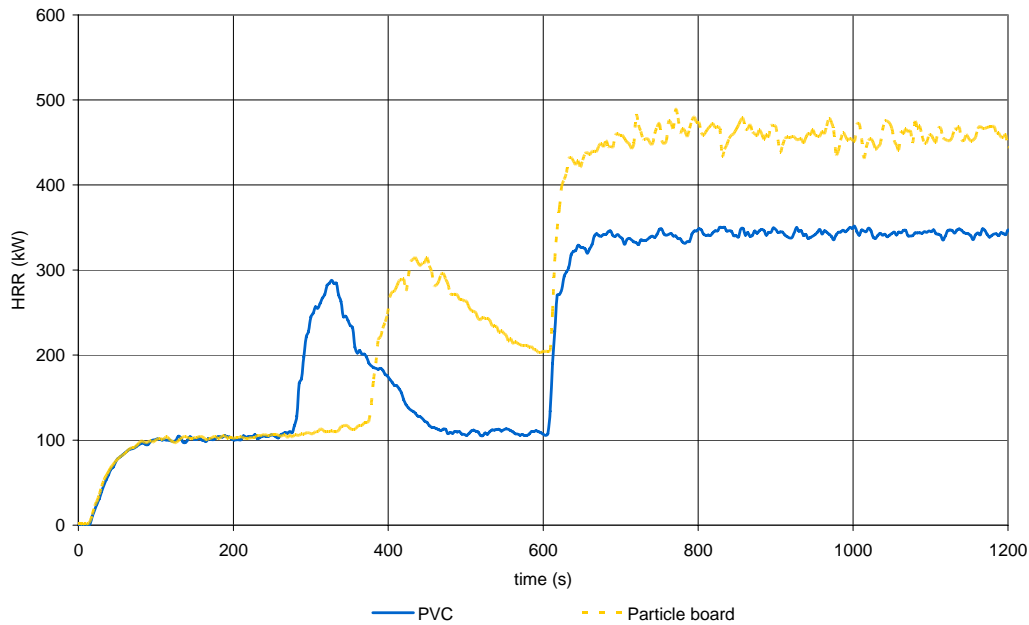

Figure 14 Scenario 1; comparison of HRR between the PVC floor covering and the particle board.

Figure 14 presents the results from the measurements on PVC and the particle board floor covering. A pilot flame was used in both experiments. As can be seen, the PVC material ignites quicker than the particle board but it is also evident that the total heat release for the particle board is larger.

Visual observations during these tests confirmed that the PVC ignited before the particle board. The pilot flame was positioned under the table in this scenario and the ignition occurred by the pilot flame. Both materials started to release combustible gases in the hot area under the table in both tests before ignition thus resulting in that almost the entire surface under the table ignited at once. The PVC material effectively stopped the flame spread outside of the hotter area and self extinguished. In the same time-period for the particle board the flame was spreading slowly outwards. Increasing the burner from 100 kW to 300 kW did not reignite the PVC material. The flame spread in the particle board continued until the burner was stopped after 20 minutes, when it slowly decreased to final self extinguishment. The larger total area contributing to the heat released for the particle board compared to the PVC explains the larger total heat release for the particle board experiment. The material damage after the test reached a distance of 1.8 meter from the burner corner for the particle board and 1.3 meter for the PVC flooring material.

In spite of the smaller amount of energy produced, the PVC floor covering experiment produced much more smoke than the particle board experiment, as can be seen from Figure 15.

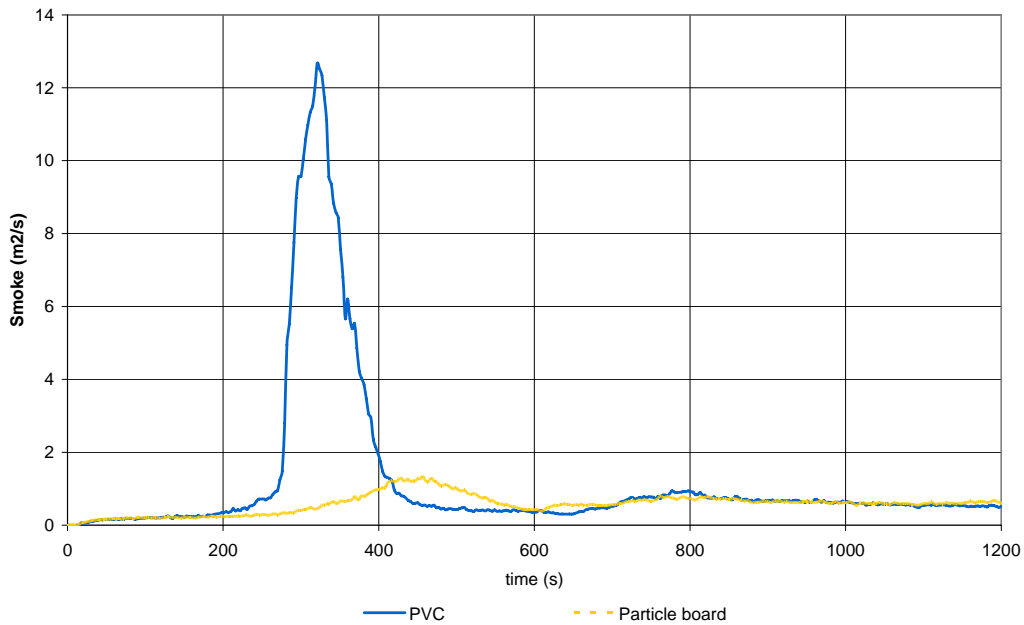

Figure 15 Scenario 1; smoke production from PVC floor covering and particle board experiments.

3.3.2 Scenario 2-3

Only one test was made in each scenario 2 and 3. It was found that the scenario 2 set-up resulted in experiments likely to be difficult to reproduce. The set-up, with a gas burner and “table” mounted in the centre of the doorway, 90 cm towards the back of the room (see Figure 6), would appear to be a worst case scenario as the floor flame spread is wind aided by doorway ventilation. That it indeed also is a worst case scenario is seen in Figure 16 where a comparison is made between scenario 1, 2 and 3 using a PVC floor covering for the experiments and no pilot flame. The problem with scenario 2 is that a small variation in fire development changes the flow of air considerably, e.g. ignition of the floor material at the left or right side of the burner, specific location of the ignition etc., will have a large influence on the total fire development. Smoke production from the experiments is shown in Figure 17.

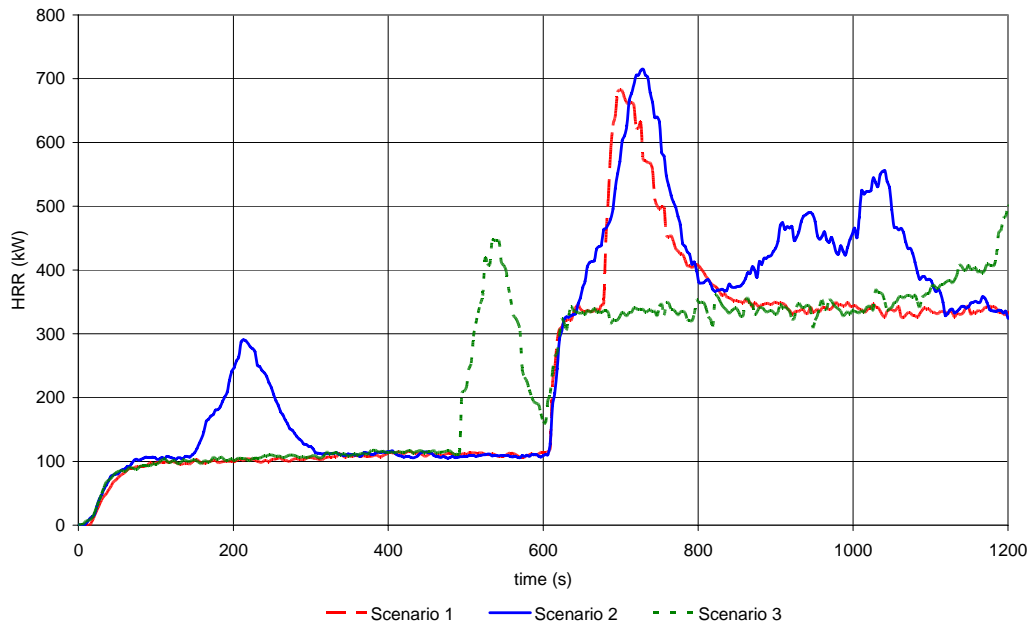

Figure 16 HRR results from PVC floor covering experiments in scenario 1,2 and 3.

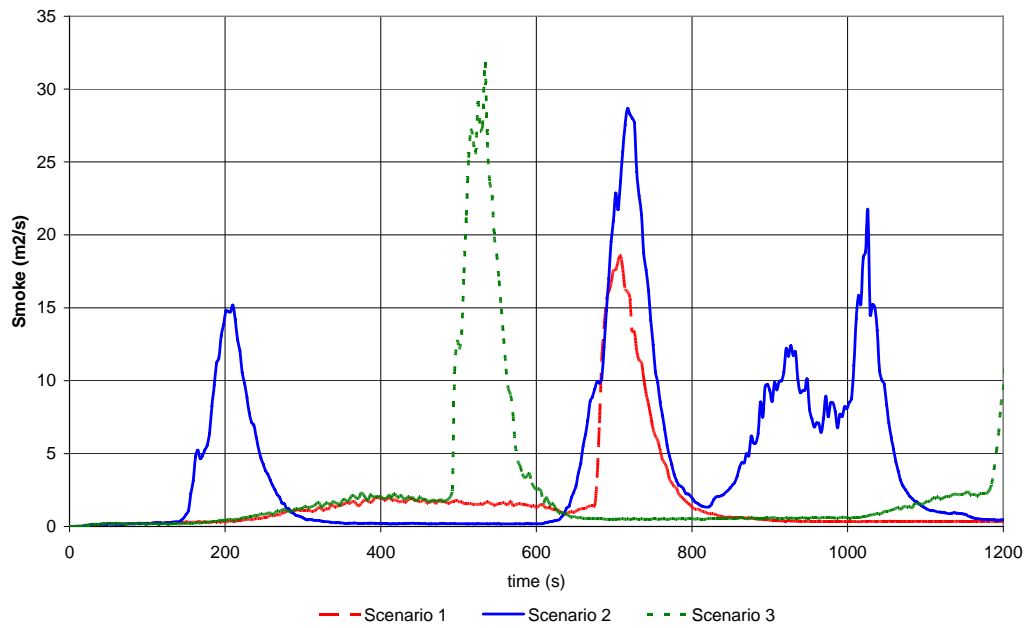

Figure 17 Smoke production from the PVC experiments in scenario 1,2 and 3.

3.3.3 Scenario 3'

For scenario 3', a "bed" was used instead of a "table" together with the gas burner, situated in the right corner closest to the doorway (see Figure 6). The result from the experiments with PVC and polypropylene floor coverings is seen in Figure 18. Once again, similar to the scenario 1 experiments, it is found that the PVC floor covering provides the fastest ignition but that total heat release is lower compared to the other material and also, that the amount of smoke is substantially larger from the PVC experiment, as can be seen from Figure 19.

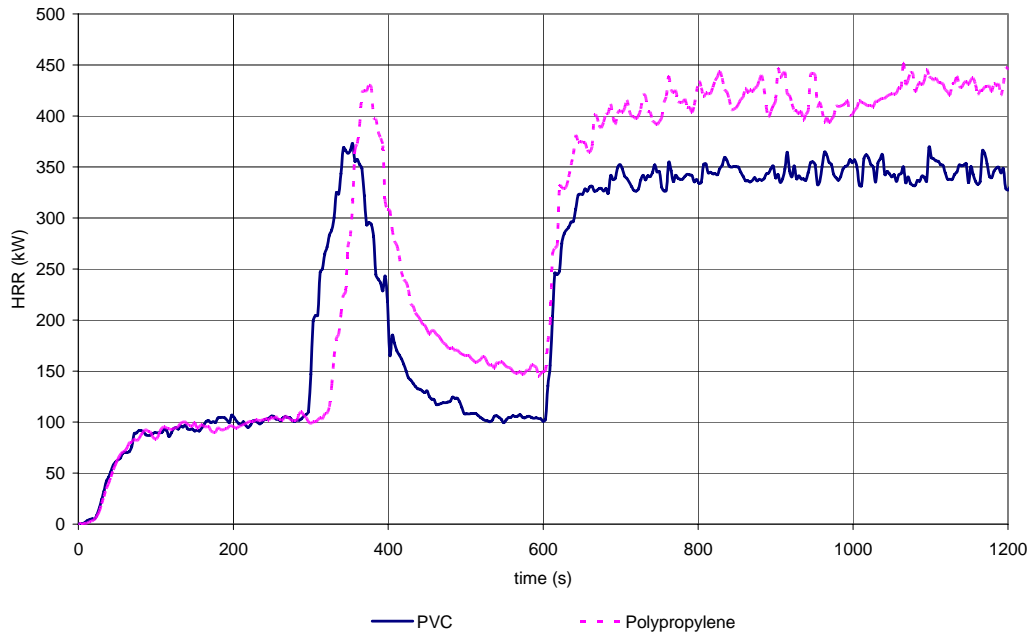

Figure 18 HRR results from scenario 3' experiments with PVC and polypropylene floor coverings.

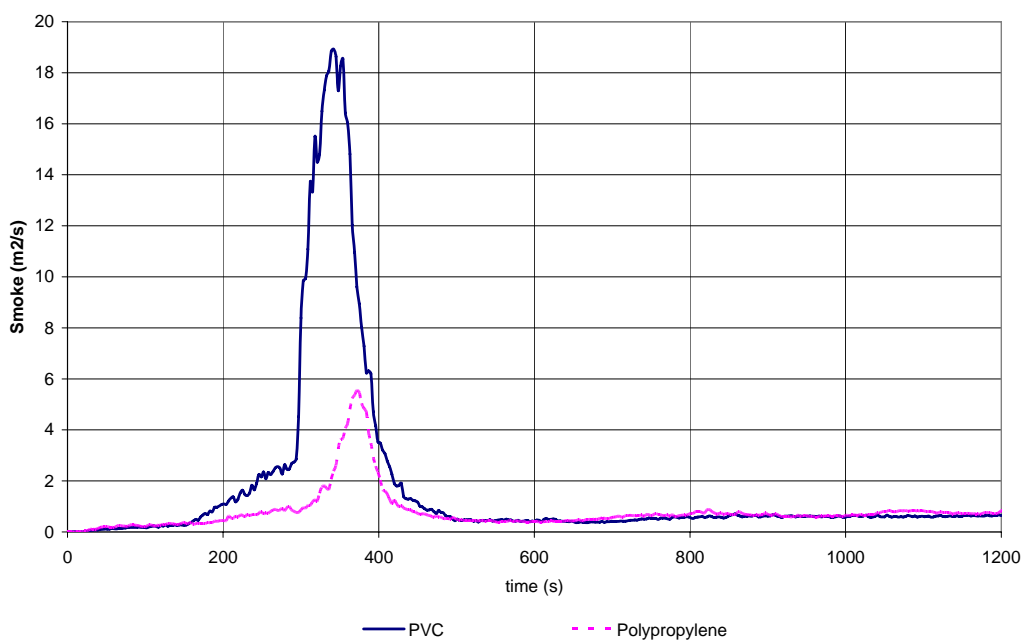

Figure 19 Smoke production from scenario 3' experiments with PVC and polypropylene floor coverings.

Similar to the comparison in scenario 1 above, visual observation confirmed the difference in ignition time shown by Figure 18. The PVC material self extinguished before the burner was increased to 300 kW at 10 minutes and was not re-ignited after the increase. The flame front in the polypropylene floor covering, however, continued even 10 minutes after the burner was stopped and eventually had to be extinguished with water. The flame front had then reached the opposite long wall and halfway through the room.

3.3.4 Scenario 4

The idea of scenario 4 was to use a pool fire instead of the standard ISO 9705 gas burner in order to produce enough energy for a flashover and at the same time provide a smoke layer that would radiate effectively towards the flooring material. Several tray diameters were tested in order to obtain a level of HRR that was suitable for a near flashover situation. Theoretically, a flashover will occur in the Room/Corner enclosure at an energy level of ~1 MW. A circular pool tray with a diameter of 0.62 meter with heptane as liquid was found to be suitable and the HRR and temperature measurements at the two different floor locations (no combustible flooring material present) is shown in Figure 20. It can be seen in Figure 20 that 1 MW is just about reached in 400 seconds and during this test, visible flames were seen at the door opening just after 400 seconds of test, indicating a flashover. As can be seen from Figure 20, the amount of fuel is just about sufficient to reach a flashover. All scenario 4 tests were made with a pilot ignition flame at the floor close to the tray.

The temperatures in Figure 20 were measured using a plate thermocouple. A correlation between heat flux levels and temperatures, measured by a plate thermocouple in the Cone calorimeter, is given in Figure 21 and it can be seen that a ~10 kW/m² radiation level is approximately equivalent to 300 °C. Comparing with the temperature profiles in Figure 20, it appears that at least within 200 seconds, the pool fire will contribute enough radiation [$T(200\text{ s}) \sim 300\text{ C} \sim 10\text{ kW/m}^2$] to sustain combustion even for the PVC floor covering as the radiation will be greater than the critical flux for PVC (see Table 3). The pool fire will produce approximately 800 kW at time 200s which is close to the value (1000 kW) usually considered as the point of flashover for a fire in the ISO 9705 Room-Corner enclosure.

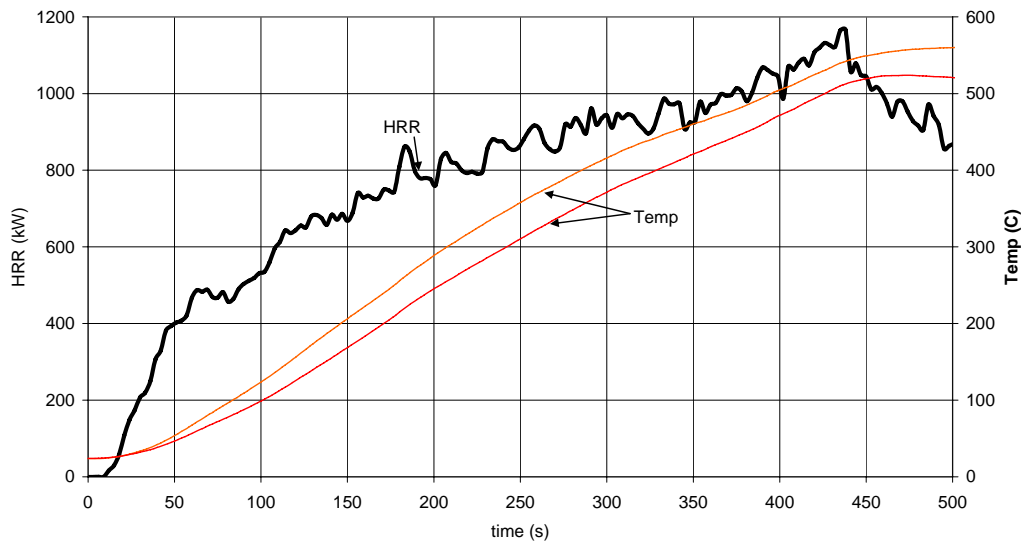

Figure 20 HRR and temperature curves for the heptane pool fire used in scenario 4.

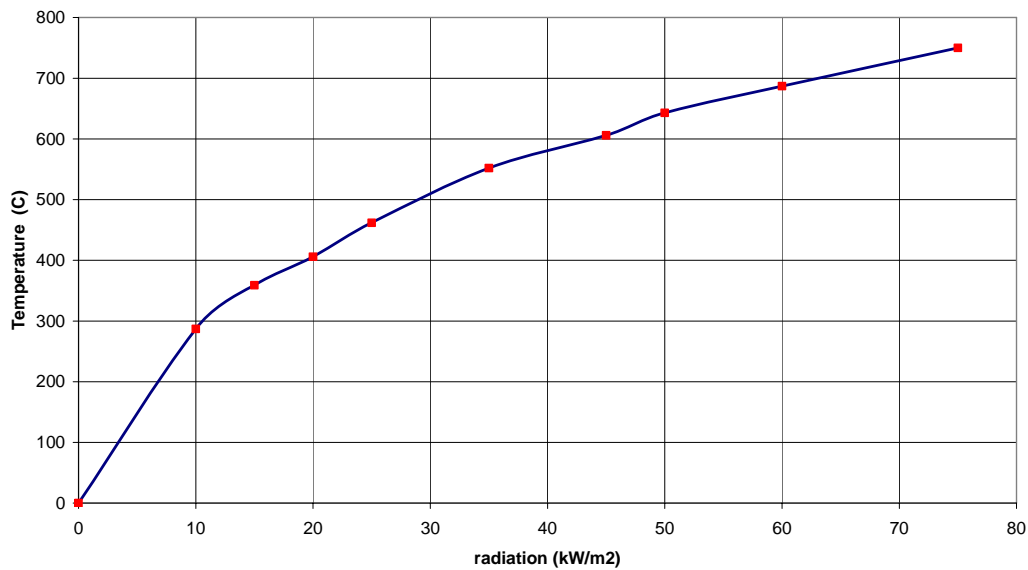

Figure 21 Temperatures and corresponding radiation levels as obtained in the Cone calorimeter.

Four different flooring materials were tested in scenario 4, PVC, particle board, linoleum and polypropylene floor covering and the results are shown in Figure 22. All experiments went to flashover as anticipated. During the tests, a pilot flame was mounted at the floor.

It was interesting to note that the fastest flashover was obtained for the material having the highest rank (B_{FL} -class) by the EN ISO 9239-1 flooring material test (the PVC material) whereas the other three (D_{FL} -class) materials kept their internal ranking, i.e. linoleum > particle board > polypropylene (the symbol “>” should be read “better than”). It is not self-evident how to determine the time for flashover from the HRR-curves given in Figure 22 even though the event itself is indisputably taking place. The time is better determined from the temperature measurements shown in Figure 23. The time to flashover is determined as when the temperature rate started to increase faster than before.

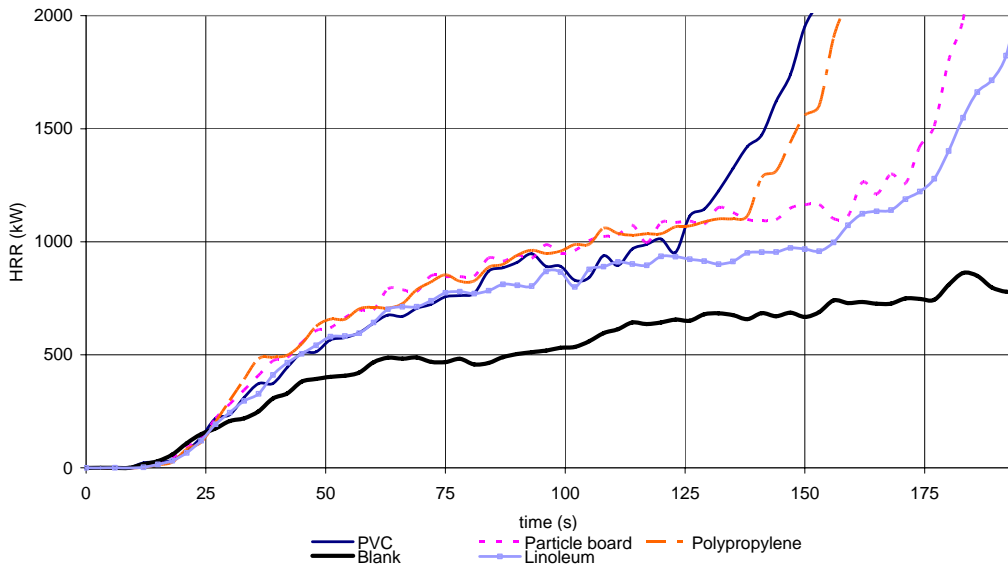

Figure 22 Flashover results for scenario 4.

It is clear that the temperature increase is more rapid when a flooring material is mounted in the enclosure, compared to when only the heptane pool fire is used (“blank” in Figure 23).

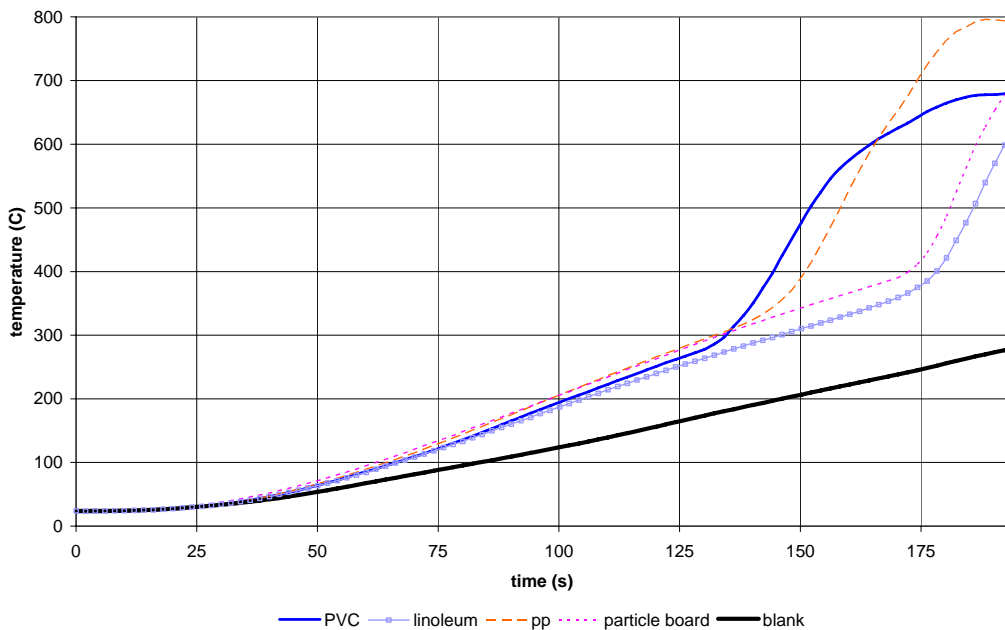

Figure 23 Plate thermoelement measurement data from the flashover experiments in scenario 4.

Estimated flashover times for the experiments are given in Table 7.

Table 7 Approximate time for flashover in scenario 4.

Material	Flashover time
PVC	135 seconds
Polypropylene	148 seconds
Particle board	175 seconds
Linoleum	180 seconds

In all the four experiments, ignition of the flooring material started by the pilot flame positioned 0.9 meter from the rear wall and the flames then spread first against the rear wall before moving out towards the doorway. This was caused by the incoming fresh air feeding the heptane fire in the rear corner.

Table 8 Flame spread characteristics for the different materials.

Material	Flame spread inwards	Flame spread half the way out to the doorway
PVC	115 seconds	138 seconds
Polypropylene	120 seconds	142 seconds
Particle board	160 seconds approx.	180 seconds
Linoleum	160 seconds	185 seconds

For safety reasons the experiments were stopped when the heat release rate was higher than 2000 kW.

As stated above, a pilot flame was used in the experiments. A comparison was also made for the particle board floor covering experiment with a test without any pilot flame, the results from the HRR-comparison can be seen in Figure 24 and the temperature comparison in Figure 25. As seen, there is a substantial difference as the time to flashover without a pilot flame is 50% longer and the pilot flame has a significant importance for the floor temperature and hence, for the time to flashover.

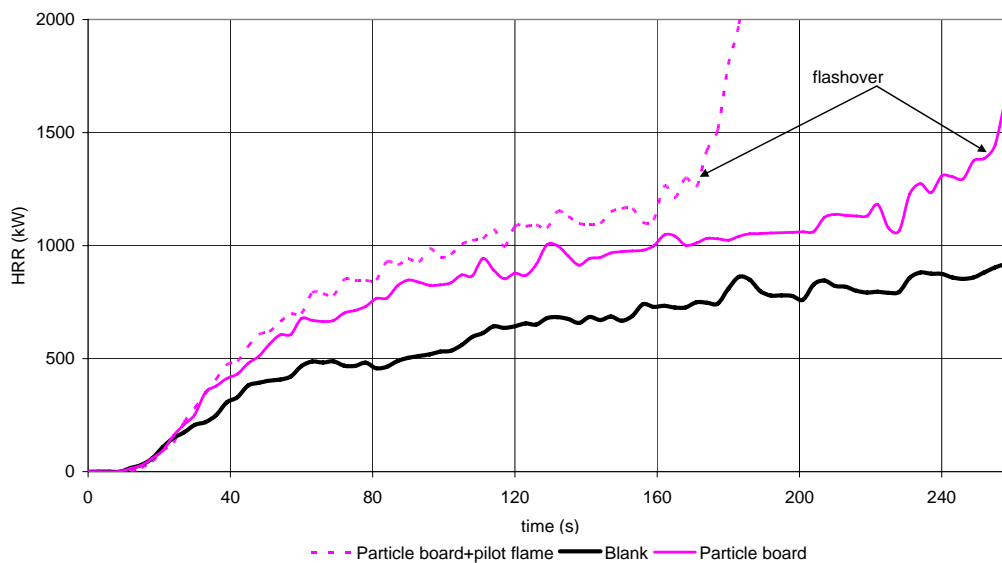

Figure 24 Comparison of flashover tests with and without a pilot flame.

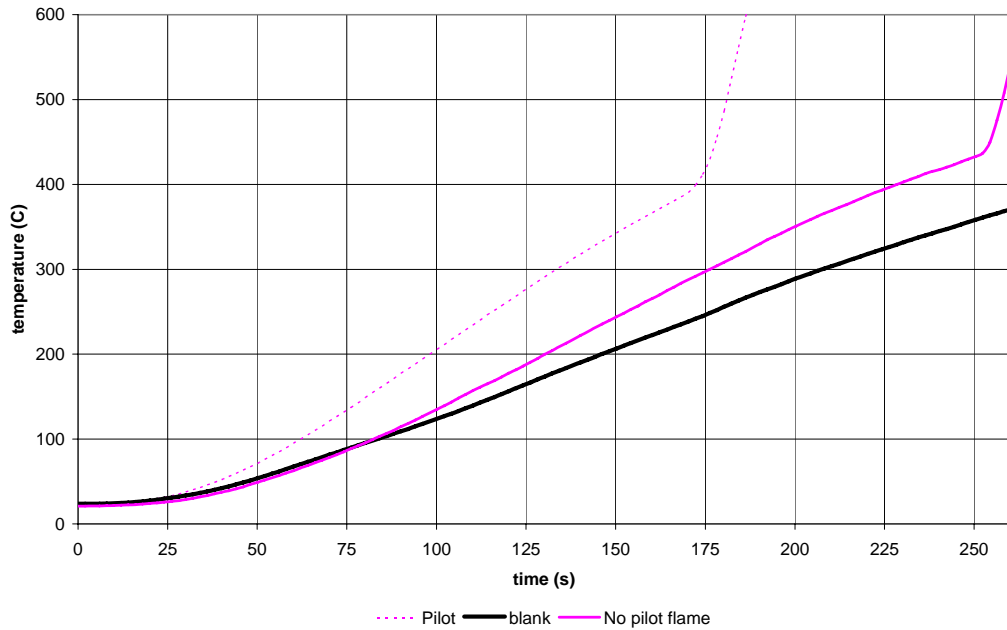

Figure 25 Temperature measurement comparisons for the particle board experiments in Figure 24.

3.3.5 Smoke from large scale experiments

Smoke production rate for the experiments in scenario 1, 2, 3, and 3' are shown in Figure 15, Figure 17 and Figure 19. The amount of smoke produced from the flashover experiments in scenario 4 were out of range for the measurement equipment used. The smoke production rates in scenario 1,2, and 3 show the same ranking as the Cone calorimeter tests, i.e. that the PVC material provides the highest amount of smoke. This is perhaps more clearly seen from the total smoke plots from scenario 1 given in Figure 26 and Figure 27.

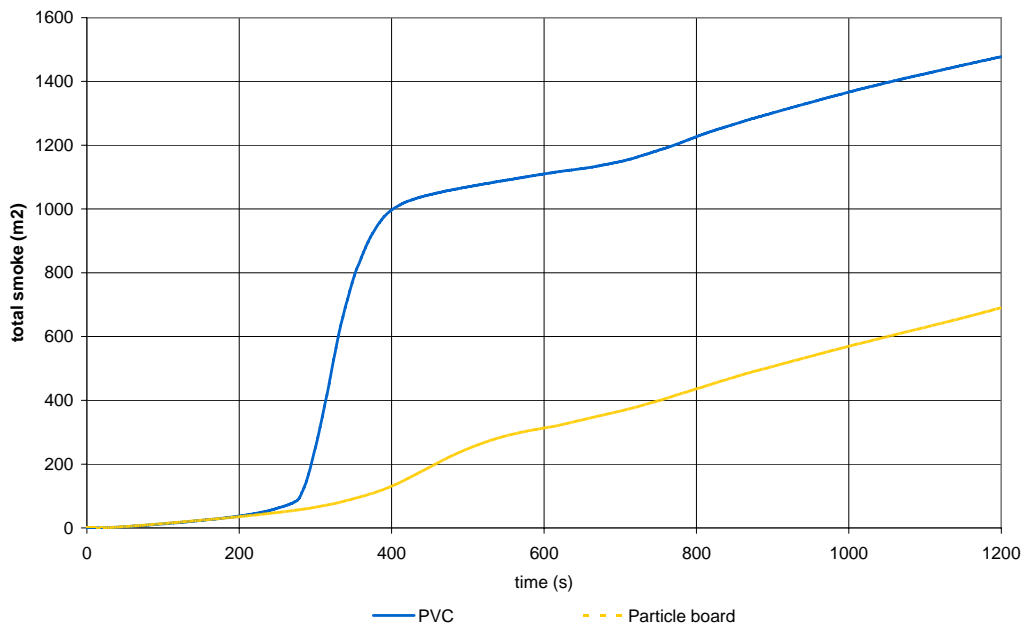

Figure 26 Total smoke production in scenario 1 fire tests (see also Figure 14 and Figure 15).

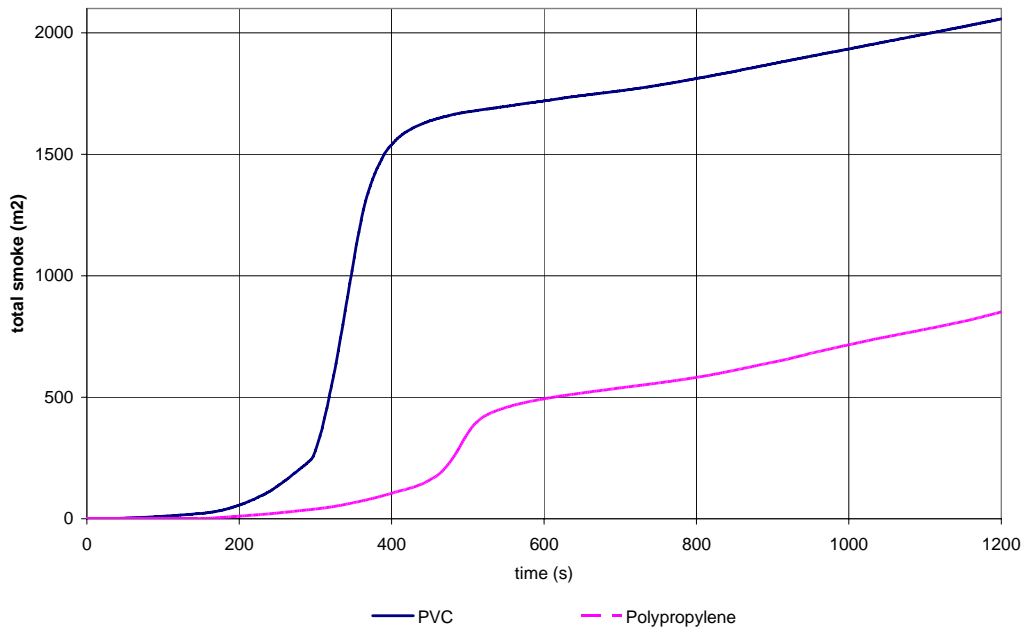

Figure 27 Total smoke production in scenario 3' fire tests (see also Figure 18 and Figure 19).

4 Discussion

A ranking of different flooring materials has been made based on three different experimental methods: two small scale methods (EN ISO 9239-1 and ISO 5660) and one large scale set up (in five different fire scenarios) using the Room-Corner enclosure scenario normally used for ISO 9705 test. A collection and summary of all “rankings” is given in Table 9. Due to limited resources the rubber material was excluded in the full scale test series.

Table 9 Ranking of flooring materials used in the project; I=“best”, V=“worst”. “-“ means no test was made.

Test	Quality	PVC	Rubber	Linoleum	Particle board	Poly-propylene
EN ISO 9239-1	<i>Euroclass</i>	<i>B_{FL-S1}</i>	<i>C_{FL-S1}</i>	<i>D_{FL-S1}</i>	<i>D_{FL-S1}</i>	<i>D_{FL-S1}</i>
	Critical heat flux	I	II	III	IV	V
	Initial rate of flame spread	V	IV	III	I	IV
	Peak smoke value	V	IV	III	I	II
	Total smoke	III	V	IV	I	II
ISO 5660	Ignition time	IV	III	I-II	I-II	V
	Peak HRR	II	V	III	I	IV
	THR	I	III	IV	V	II
	Peak smoke value	V	IV	II	I	III
	Total smoke	V	IV	III	I	II
Large* scale	Scenario 4: Time to flashover	IV	-	I	II	III
	Scenario 1: time to ignition	II	-	-	I	-
	Scenario 1: THR	I	-	-	II	-
	Scenario 1: total smoke	II	-	-	I	-
	Scenario 3': time to ignition	II	-	I	-	-
	Scenario 3': THR	I	-	II	-	-
	Scenario 3': Total smoke	II	-	I	-	-

*Only data for scenario 1, 3' and 4 are given since a single material (the PVC floor covering) was tested in scenario 2 and 3

Generally speaking, based on the results in Table 9, it is clear that the PVC flooring material used in this project obtains its high rank in the European classification system purely due to the fact that it will not continue to burn if the radiation level is below 9 kW/m².

Obviously, such a quality is of great value with regards to fire safety but it seems that other qualities such as the rate of flame spread, heat release rate, total energy and smoke production should be included in the overall quality mark of flooring materials. In spite of the low flame spread quality the PVC flooring material came out as the worst material to use in the large scale enclosure tests with regards to time to ignition, smoke and time to flashover. It should be pointed out that this observation is for this material and should of course not be considered as general for all Class B_{FL} materials.

Another important quality with regards to fire hazards is smoke toxicity. It has previously been shown¹³ that HCl produced from PVC flooring materials will make a significant contribution to the overall fire toxicity. Toxicity requirements are given for products used on ships and trains and is currently also discussed for building materials.

An interesting observation was that the fire behaviour of the materials used was repeated very well in all test methods. It is thus seen that the type of PVC floor covering used in the project ignites fastest of all tested materials at high enough radiation levels, but also that the flame spread on PVC stopped effectively when the radiation level becomes low enough. The polypropylene sample had the lowest rank in the EN ISO 9239-1 test and this bad flame spread quality appeared also in the large scale test, with a continuous flame spread long time after the gas burner was turned off. Good reproducibility of fire qualities was also found for smoke (all tests) and total energy production (Cone Calorimeter and large scale).

A notation to make is that the maritime industry has developed a more advanced radiation panel test for flooring material than ISO EN 9239-1 through the IMO RES A.653 standard. The standard stipulates a higher radiation level compared to ISO EN 9239-1 and beside the critical flux level requirement, also includes speed of flame spread, total heat release and maximum heat release rate as part of the classification. In addition there are smoke toxicity requirements for flooring materials at sea (through the ISO 5659-2 "smoke box" test). Similar higher level radiation panels are also used in national legislation. Great Britain and Belgium is using the British test, BS 476 part 7 panel, with a heat flux level of around 40 kW/m². The British standard also introduce a time limit for the flame spread.

Because of the Belgium legislation, a proposals for a level of 11 kW/m² for class B_{FL} was discussed during the development of the requirements for the Euroclasses but was rejected. The work presented in this report shows that the chosen level of critical flux for class B_{FL}, 8 kW/m², is probably too low. Also ISO TC92 SC1 WG3 has developed a procedure using ISO 9239 with higher levels as a request from countries such as Japan. The new standard ISO 9239-2 are testing the flame spread characteristics in a heat flux level of 25 kW/m².

5 Conclusions

A key point for the project was to investigate if the EN ISO 9239-1 test was sufficient to provide information regarding the behaviour of flooring materials as a flashover situation is approached. The conclusion is that additional data is needed to create enclosures with minimum risk and impact on flashover fires. The project has also shown that such data are available by the small scale ISO 5660 Cone Calorimeter test method. Some data are also already available from measurements made in EN ISO 9239-1 although they are not used for classification of the material (rate of flame spread) or have too unrestricted limits to be of any real value to fire safety engineering (smoke).

The project has also demonstrated that the choice of flooring material has significant bearing on the time to flashover in the Room-Corner test scenario, on the amount of smoke produced and on the total heat production. The study confirms previous studies and correlations made between room corridor tests and small scale tests such as ISO 9239 part 1 and 2 and ISO 5660. These studies also found that it is not sufficient to only consider flame spread at limited heat flux levels to assess the fire risk of floor coverings but that also parameters such as flame spread at higher levels, ignition behaviour, heat and smoke release are important.

It should be pointed out that the results of the materials in this project should not be considered as behaviour for all materials in the same product family or class.

References

- ¹ Hertzberg T., Blomqvist P., Tuovinen H., *Reconstruction of an arson hospital fire*, Fire & Materials, Volume 31:4, 2007
- ² Hertzberg T., Blomqvist P., Tuovinen H., *Measurement and simulation of fire smoke*, SP Technical Research Institute of Sweden, Report 2005:29.
- ³ *Branden i Göteborg den 29-30 oktober 1998, en sammanfattning*, SOU 2000:113, Försvarsdepartementet
- ⁴ Ingason, Haukur, Wickström, Ulf, Van Hees, Patrick, *The Gothenburg discotheque fire investigation*, SP Swedish National Testing and Research Institute, Interflam 2001. International Interflam Conference. 9th proceedings. Vol. 2. September 17-19, pages 965-976.
- ⁵ Tu K-M., Davis S., *Flame spread of carpet systems Involved in room fires*, NIST report NBSIR 76-1013
- ⁶ Ohlemiller T.J., *Flammability of real objects: A progress report*, NISTIR 6030, Conference paper, 13th meeting of the UJNR panel on fire research and safety, March 1996.
- ⁷ Nevilla, A , Mc Arthur and Jolliffe, *C Development of a demountable fire test corridor for assessment of floor coverings*, Proceedings of The Fifth International Symposium on Fire Safety Science, pp1273-1284, Melbourne, Australia, 3-7 March, 1997.
- ⁸ Ames, S, Colwell, R, Shaw, K, *The fire behaviour and fire testing of floor coverings. Development and evaluation of small and large scale tests.*, Interflam'96 proceedings pp 69-78, England, march 1996
- ⁹ Van Hees, Patrick, *Wind aided flame spread of floor coverings – Meestroomvlamuitbreiding bij vloerbekledingen – Ontwikkeling en validatie van grootschalige en kleinschalige meettechnieken*, PhD Dissertation, University of Gent 1995.
- ¹⁰ VAN HEES, Patrick and VANDEVELDE, Paul, *Wind aided flame spread of floor coverings - development and evaluation of small and large scale tests*, Interflam'96 proceedings pp 57-68, England, march 1996.
- ¹¹ International Standard – Fire tests – *Reaction to fire – Rate of heat release from building products* (Cone calorimeter method), ISO 5660 – 1: 1993, International Organization for Standardization, Geneva, 1993
- ¹² *International Standard – Fire tests -- Full-scale room test for surface products* ISO 9705:1993(E). International Organization for Standardization, Geneva, 1993
- ¹³ Hertzberg T., Blomqvist P., Låstbom L., *Influence of HCl and PVC-smoke on isolated and perfused guinea pig lungs*, SP Technical Research Institute of Sweden, Report 2006:57.

SP Technical Research Institute of Sweden develops and transfers technology for improving competitiveness and quality in industry, and for safety, conservation of resources and good environment in society as a whole. With Sweden's widest and most sophisticated range of equipment and expertise for technical investigation, measurement, testing and certification, we perform research and development in close liaison with universities, institutes of technology and international partners.

SP is a EU-notified body and accredited test laboratory. Our headquarters are in Borås, in the west part of Sweden.

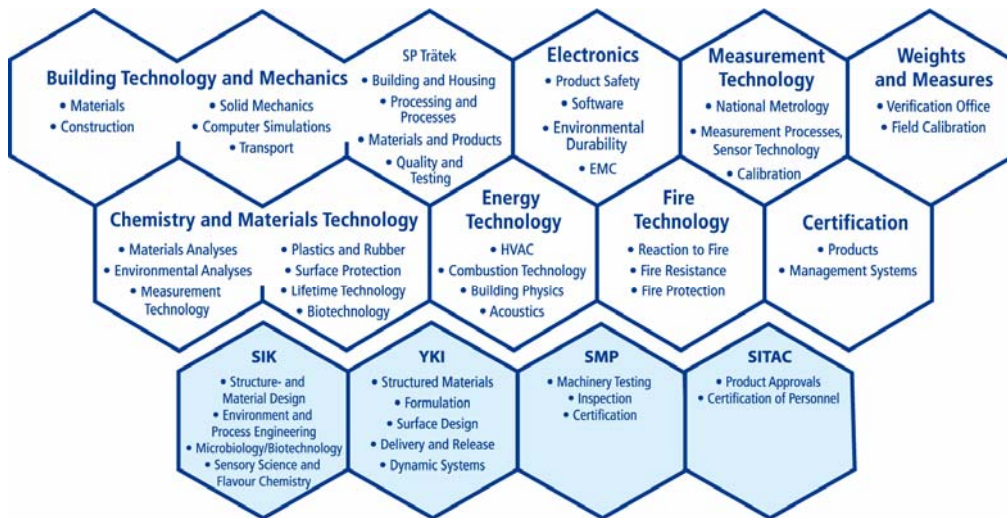

SP is organised into eight technology units and four subsidiaries



SP Technical Research Institute of Sweden

Box 857, SE-501 15 BORÅS, SWEDEN

Telephone: +46 10 516 50 00, Telefax: +46 33 13 55 02

E-mail: info@sp.se, Internet: www.sp.se

www.sp.se

Fire Technology

SP Report 2007:29

ISBN 978-91-85533-89-3

ISSN 0284-5172

A Member of

