

# Noncontacting Measurement of Power in Microstrip Circuits

K. Yhland and J. Stenarson

SP Swedish National Testing and Research Institute  
Box 857, SE 501 15 Borås, Sweden  
klas.yhland@sp.se

**Abstract**—This paper describes the use of a loop coupler probe for noncontacting measurement of power in microstrip circuits. The additional uncertainties, compared to contacting measurements, are investigated. The sensitivity of the coupling to positioning errors gives an uncertainty contribution in the same order as when using galvanically contacting techniques. The uncertainty due to probe directivity is comparable to the uncertainty when galvanically contacting internal parts of the circuit board. The impact of the probe on the waves on the circuit board is also investigated. In addition to the laboratory investigation of a probe, noncontacting measurements on a series produced microwave system are included. They agree well with contacting measurements.

## I. INTRODUCTION

Noncontacting measurement of power (and S-parameters) on planar circuits offers a convenient way of measurement on internal parts of planar microwave systems. In this case galvanically contacting methods would require rerouting of the signal path or disassembly of the circuit board which are laborious operations.

Several techniques have been presented for vector corrected measurements of power and/or S-parameters [1–7]. However, none of these techniques are suitable for scalar measurement. This is because they are all based on techniques sensing either E or H field [1–6] or a combination of such techniques [7] and, hence, offer no inherent separation between the forward and reverse waves.

Therefore, we present the use of a loop coupler placed above a planar transmission line. The loop coupler has been used before, but then mainly as a probe in coaxial or wave-guide structures [8–10].

The loop coupler has several advantages over the E or H field probes. It has an inherent directivity and, therefore, does not require vector error correction as in [1–7] to allow power measurements. Scalar calibration is sufficient. Moreover, the loop coupler does not require repositioning of the probe as in [1–6].

In this paper we investigate the suitability of a loop coupler probe for noncontacting measurement of power in microstrip circuits. We give measurements of coupling and directivity and their sensitivity to positioning errors

over the planar transmission line. We also show results from measurements of internal signals in a microwave link, these results are compared with measurements using galvanically contacting techniques.

## II. PROBE DESIGN AND TEST SETUP

The probe under test is made from two 0.8 mm diameter semirigid cables with the outer conductors soldered in parallel. At one end they have 2.92 mm coaxial connectors and at the other end the inner conductors form a circular loop joining the two cables. The probe is covered with eccosorb on two sides. The test setup is shown in Fig. 1. It consists of the probe mounted on microtranslators allowing x-y-z positioning with 5  $\mu\text{m}$  resolution. The probe was used to measure power on a microstrip board with thickness 0.38 mm and  $\epsilon_r = 2.33$  giving a 50  $\Omega$  line width of 1.12 mm.

The transversal positioning of the probe was done relative to the center of the conductor which was found using a magnifying glass. The vertical positioning was done relative to the conductor surface which was found by lowering the probe until dc-contact was reached with the microstrip line. When changing between substrates, the repeatability is estimated to 50  $\mu\text{m}$  for the transversal position and 5  $\mu\text{m}$  for the vertical position.

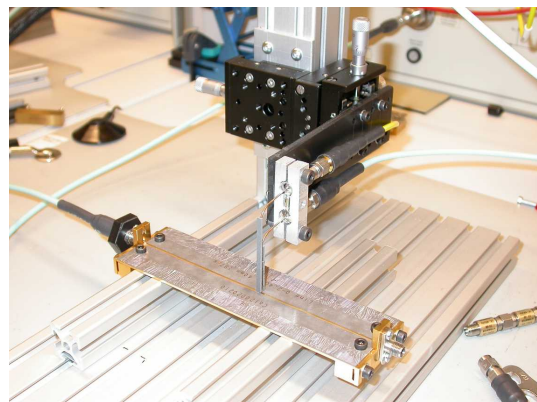

Fig. 1. The test setup

### III. MEASUREMENTS

When using the probe for power measurements with e.g. a spectrum analyzer or a power meter this will require calibration of the probe coupling versus frequency. This is done using a calibration substrate of the same type and conductor width as the DUT (device under test) with coaxial connectors at its ends allowing contacting measurements. The calibration can be done with a power meter, spectrum analyzer or a vector network analyzer (VNA). In this work we use a VNA. Measurements up to 40 GHz are included. We have, however, had problems with sensitivity to objects in the vicinity of the probe at frequencies above 30 GHz.

#### A. Coupling

The coupling was measured with an HP 8510C VNA using a two port test set. Before measurement a SOLT calibration was made in a 2.92 mm coaxial interface, see Fig. 2. The second port of the microstrip board and the second port of the loop coupler were terminated with low reflective loads.

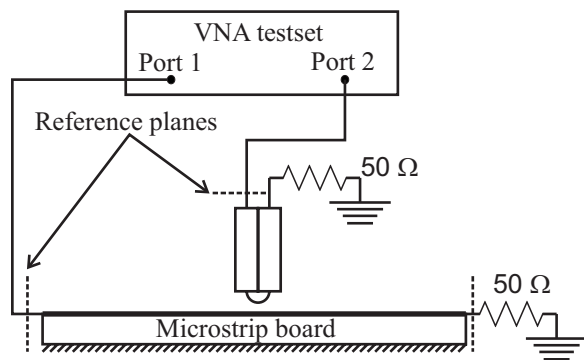

Fig. 2. Block-diagram of the setup used to measure probe coupling

Fig. 3 shows the measured coupling of the probe versus frequency and Fig. 4 shows the coupling versus vertical position over the center of the conductor. At 250  $\mu\text{m}$  height the sensitivity to the vertical position is 0.015 dB/ $\mu\text{m}$ . The sensitivity increases rapidly below 250  $\mu\text{m}$  and is 0.025 dB/ $\mu\text{m}$  at 100  $\mu\text{m}$ .

When measuring a DUT it is desirable not to load the circuit too much. Therefore, and to keep the vertical sensitivity low, this study was made with 250  $\mu\text{m}$  as starting point. At this point the coupling is less than -23 dB over the entire frequency range and a 5  $\mu\text{m}$  repeatability of the vertical position corresponds to 0.075 dB uncertainty. In the following diagrams we study the effect of probe positioning on the coupling. To limit the amount of diagrams, the study is made at 10 GHz and 20 GHz. Figs. 5 and 6 show the coupling measured versus transversal position. As can be seen the coupling is insensitive to transversal

positioning errors when placed over the middle of the microstrip conductor. A 50  $\mu\text{m}$  repeatability of the transversal center position corresponds to 0.05 dB uncertainty.

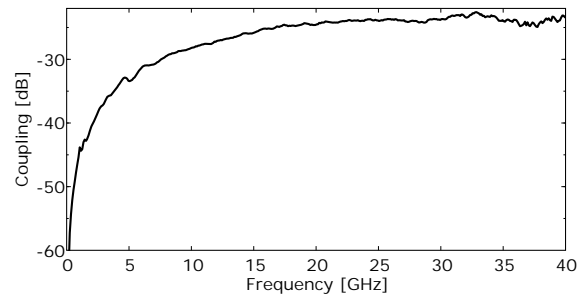

Fig. 3. Coupling vs frequency, probe centered 250  $\mu\text{m}$  above the conductor

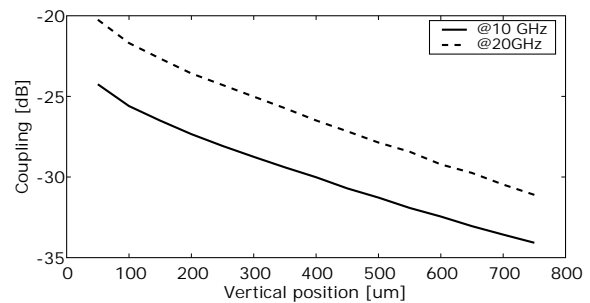

Fig. 4. Coupling vs vertical position centered over the conductor

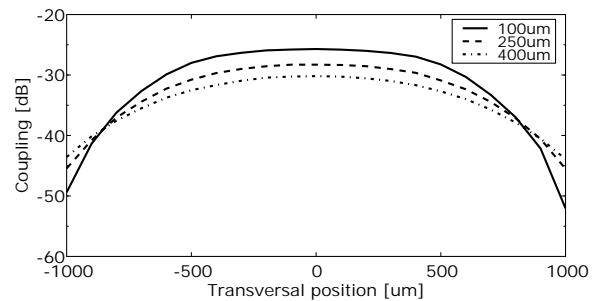

Fig. 5. Coupling vs transversal position at 10 GHz

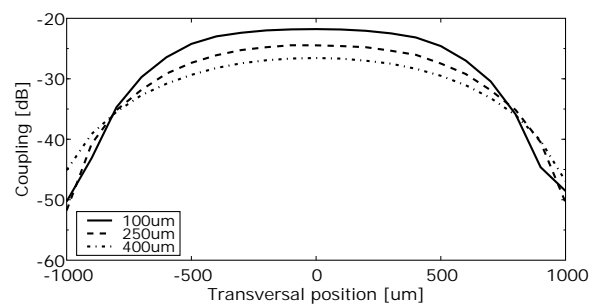

Fig. 6. Coupling vs transversal position at 20 GHz

## B. Directivity

The directivity was measured with the VNA HP 8510C and a direct access receiver testset connected as in Fig. 7.

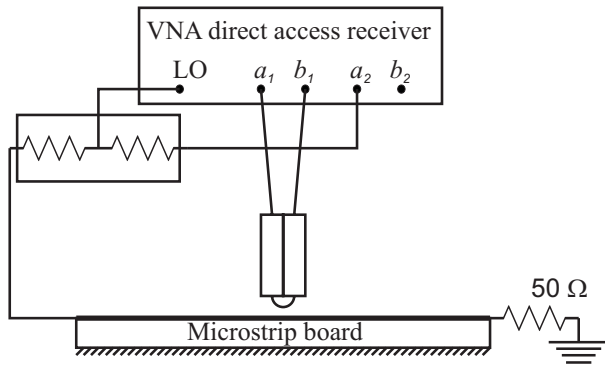

Fig. 7. Block-diagram of the setup used to measure probe directivity

The power splitter and the connection to the testset port  $a_2$  were used to assure phase locking of the VNA even when the signals from the probe were weak. The directivity is calculated as  $b_1/a_1$ . This is a reasonable method if the reflection from the 50  $\Omega$  load is low. In the test setup the planar transmission line is long which allows for time gating which further reduces the reflection as seen into the 50  $\Omega$  load. Furthermore, the measurement requires a good balance between the  $a_1$  and  $b_1$  receivers. This was checked before measurement. Fig. 8 shows the directivity of the probe versus frequency. The decrease of the measured directivity at low frequencies is probably an error caused by the time gating. Fig. 9 shows the directivity versus vertical position over the center of the conductor and Figs. 10 and 11 show the directivity measured versus transversal position. Similar to the coupling, the directivity is insensitive to transversal positioning errors when placed over the middle of the microstrip conductor.

The uncertainty in the measured wave level caused by the directivity depends on the magnitude of the reverse wave. If this level is low, say 15 dB below the measured wave, a directivity better than -25 dB corresponds to an uncertainty of 0.09 dB which is in the same order of magnitude as other contributions. If the reverse wave has the same magnitude as the forward wave, this uncertainty contribution will increase to 0.5 dB.

The directivity measurements were verified by connecting a high reflective load (a short circuit) to the second port of the microstrip board and measuring the ripple versus frequency caused in the coupling measurements in the previous section. Under the condition that the probe is symmetric (directivity and coupling for both probe ports are equal) the ripple is a measure of the directivity of the probe.

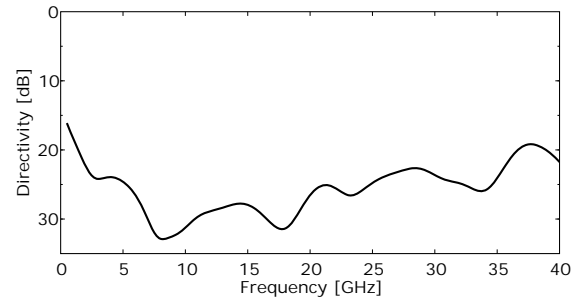

Fig. 8. Directivity vs frequency, probe centered 250  $\mu\text{m}$  above the conductor

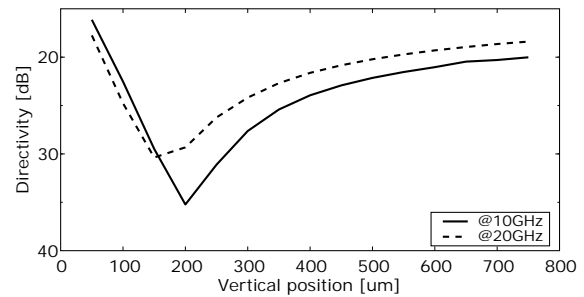

Fig. 9. Directivity vs vertical position at 10 GHz and 20 GHz

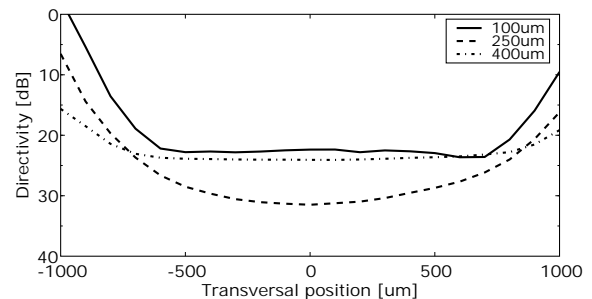

Fig. 10. Directivity vs transversal position at 10 GHz

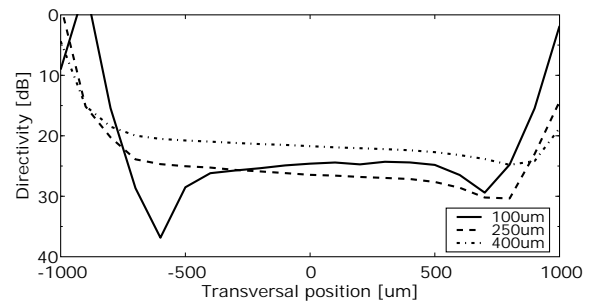

Fig. 11. Directivity vs transversal position at 20 GHz

## C. Impact on the circuit board transmission and reflection

To give realistic measurements, it is important that the probe does not alter the operating conditions of the DUT.

Therefore, the loading of the probe on the planar circuit was investigated by measuring the change in transmission and reflection coefficients of the microstrip line on the circuit board. This was done versus frequency (see Figs. 12 and 13) and vertical probe position (see Figs. 14 and 15). The change is measured relative to the transmission and reflection when the probe is raised 10 mm above the circuit board.

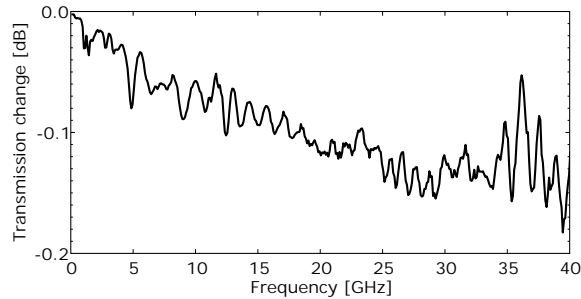

Fig. 12. Transmission change vs frequency, probe centered 250  $\mu\text{m}$  above the conductor

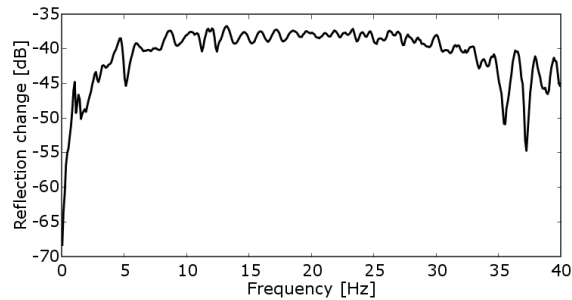

Fig. 13. Reflection change vs frequency, probe centered 250  $\mu\text{m}$  above the conductor

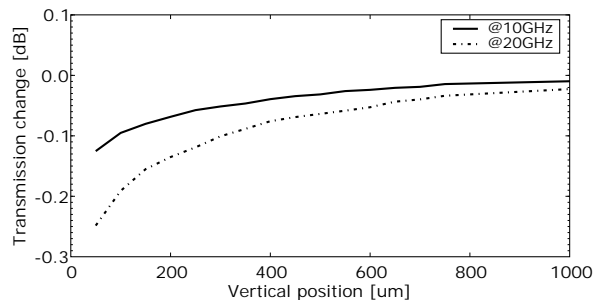

Fig. 14. Transmission change vs vertical position at 10 GHz and 20 GHz

#### D. Test on a microwave system

To test the methods suitability for microwave systems where available 50  $\Omega$  lines are short it was applied to an oscillator doubler chain operating at 5.19 and 10.38 GHz.

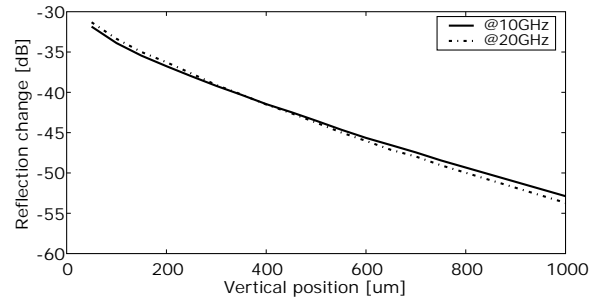

Fig. 15. Reflection change vs vertical position at 10 GHz and 20 GHz

The available 50  $\Omega$  lines were about 6 mm long. The measurements were made with a spectrum analyzer and a probe, similar to the one above, made from 1.2 mm diameter semirigid cable. Verifying measurements were made by breaking the signal path on the circuit board and soldering a small tab extending to the substrate edge where a coaxial connector was clamped. The loss in this transition was not corrected for. Table I shows the results.

TABLE I  
RESULTS FROM AN APPLICATION

	Probed measurement	Verifying coaxial measurement
First doubler output 5.19 GHz	10.8 dBm	10.2 dBm
Second doubler output 10.38 GHz	6.5 dBm	5.8 dBm

The probed power levels are higher than the coaxially measured ones. The discrepancies can be explained by the loss in the coaxial connector clamped to the circuit board edge, the uncertainty contributions described earlier in this paper and uncertainties in the calibration of the probe.

#### IV. DISCUSSION AND CONCLUSION

We have investigated the suitability of a loop coupler type probe for noncontacting measurement on microstrip circuits. The uncertainties due to positioning repeatability are in the order of 0.1 dB which is in the same order as that of a calibrated power sensor.

The uncertainty due to directivity depends on the DUT but we believe it compares well to the uncertainties when making contacting measurements to internal parts of a microwave system because this requires rerouting of signal paths or disassembly of the microwave system.

We believe the loop coupler is a good candidate for noncontacting measurement of power in planar circuits because it gives performance comparable to competing methods and is less laborious than they are.

## V. ACKNOWLEDGMENT

The authors thank the Swedish metrology council and VINNOVA Swedish Agency for Innovation Systems for financial support. We also thank Cascade Microtech for manufacturing probes and Ericsson AB for their cooperation and for testing the technique in a series produced microwave system.

## REFERENCES

- [1] G. David, W. Schroeder, D. Jäger, and I. Wolff, "2d electro-optic probing combined with field theory based multimode wave amplitude extraction: a new approach to on-wafer measurement," in *IEEE International Microwave Symposium Digest*, 1995.
- [2] G. Yingjie and I. Wolff, "A miniature magnetic field probe for measuring fields in planar high-frequency circuits," in *IEEE International Microwave Symposium Digest*, 1995.
- [3] G. Yingjie and I. Wolff, "A new miniature magnetic field probe for measuring three-dimensional fields in planar high-frequency circuits," *IEEE Transactions on Microwave Theory and Techniques*, vol. 44, no. 6, pp. 911–18, 1996.
- [4] G. Yingjie and I. Wolff, "Measurements of field distributions and scattering parameters in multiconductor structures using an electric field probe," in *IEEE International Microwave Symposium Digest*, 1997.
- [5] S. S. Osofsky and S. E. Schwarz, "A non-contacting probe for measurements on high-frequency planar circuits," in *IEEE International Microwave Symposium Digest*, 1989.
- [6] S. S. Osofsky and S. E. Schwarz, "Design and performance of a non-contacting probe for measurements on high-frequency planar circuits," *IEEE Transactions on Microwave Theory and Techniques*, vol. 40, no. 8, pp. 1701–8, 1992.
- [7] J. Stenarson, K. Yhland, and C. Wingqvist, "An in-circuit, non-contacting, measurement method for s-parameters and power in planar circuits," *IEEE Transactions on Microwave Theory and Techniques*, vol. 49, no. 12, pp. 2567–2572, 2001.
- [8] P. Lombardini, R. Schwartz, and P. Kelly, "Criteria for the design of loop-type directional couplers for the l band," *IRE Transactions on Microwave Theory and Techniques*, vol. 4, no. 4, pp. 234–239, 1956.
- [9] B. Maher, "An l-band loop-type coupler," *Transactions on Microwave Theory and Techniques*, vol. 9, no. 4, pp. 362–363, 1961.
- [10] F. De Groote, J. Verspecht, C. Tsironis, D. Barataud, and J.-P. Teyssier, "An improved coupling method for time domain load-pull measurements," in *65th ARFTG*, 2005.