

Noncontacting measurement of reflection coefficient and power in planar circuits up to 40 GHz

K. Yhland, J. Stenarson, and C. Wingqvist

SP Technical Research Institute of Sweden

Box 857, 501 15 Borås, Sweden

email: klas.yhland@sp.se

Abstract—This paper describes the use of loop-coupler probes for noncontacting measurement of power and reflection coefficient in microstrip circuits up to 40 GHz. The inherent directivity of the loop-coupler probe makes it suitable for use with scalar measuring instruments such as power meters and spectrum analyzers. The probe coupling and directivity and their sensitivity to probe positioning errors are investigated. The results are summarized in a simple uncertainty budget. Measurements of reflection coefficient with a vector network analyzer are also presented and verified by coaxially contacting measurements.

I. INTRODUCTION

In development and production of microwave systems there is often a need to measure power and reflection coefficient on sub-circuits, especially for tuning, testing, and failure analysis. It is often difficult to use galvanically contacting methods because they require rerouting of the signal path or disassembly of the circuit board which are laborious operations and often not feasible. This need can be met by a noncontacting measurement technique.

Several noncontacting techniques have been proposed for the solution of this problem [1–8]. But they rely on separate measurement of the E- and/or H-field which inherently lacks directivity and thus they are inappropriate for scalar measurements. Furthermore, when using them with a vector network analyzer (VNA), E- and H-field probes give problems with ratioing due to voltage or current nulls associated with highly reflective standards [7, 8].

The use of a loop-coupler to obtain a directive probe for noncontacting measurements on microstrip was reported in [9]. For waveguides, the loop coupler was proposed in [10] and today it is commercially available for coaxial and waveguide structures. The loop-coupler has the advantage of separating the forward and backward waves on a transmission line. Furthermore, it does not cause ratioing problems due to voltage or current nulls on the conductor.

However, in [9] only results for power measurements were presented. In addition problems with repeatability above 30 GHz were reported.

This paper presents results on both reflection coefficient and power measurements up to 40 GHz for two different probe sizes. The earlier reported problems with repeatability above 30 GHz are now reduced. Results on the sensitivity to positioning errors are presented at 10, 20, 30 and 40 GHz together with a simple uncertainty budget.

II. PROBE DESIGN AND TEST SETUP

The probes are made from two semirigid cables with the outer conductors soldered in parallel. At one end they have 2.92 mm coaxial connectors and at the other end the inner conductors form a circular loop joining the two cables, see Fig. 1. The probes are covered with eccosorb on two sides. Two probes have been investigated, one made from 0.86 mm diameter cable and the other from 0.51 mm diameter cable. The test setup is shown in Fig. 2. It consists of a probe mounted on microtranslators allowing x-y-z positioning with 5 μm resolution. The probe was used to measure power and reflection coefficient on a microstrip board with thickness 0.38 mm and $\epsilon_r = 2.33$ giving a 50 Ω line width of 1.12 mm. The transversal positioning of the probe was done relative



Fig. 1. The loop-coupler probe without eccosorb

to the center of the conductor which was found using a magnifying glass. The vertical positioning was done relative to the conductor surface which was found by lowering the probe until dc-contact was reached with the microstrip line. When changing between substrates, the repeatability is estimated to 50 μm for the transversal position and 5 μm for the vertical position.

The problem with repeatability above 30 GHz reported in [9] was caused by radiation from a slot in the coaxial to microstrip transition on the microstrip board. The problem

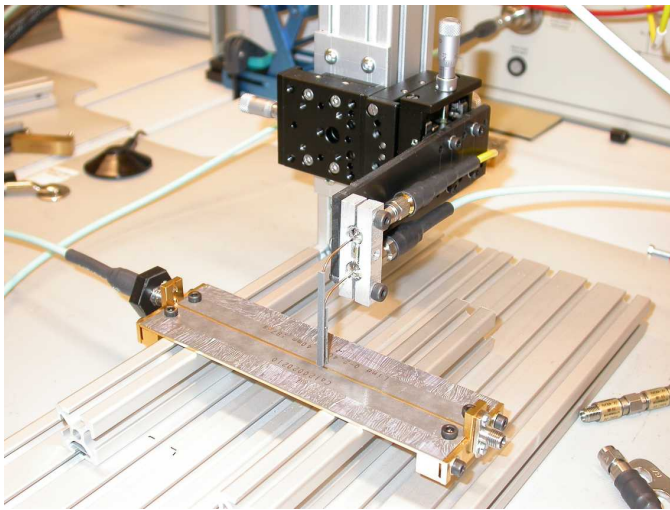

Fig. 2. The test setup

occurred when placing the probe within a few centimeters from the transition. This slot is now covered with eccosorb.

III. POWER

As opposed to the probes used in [7, 8], the loop-coupler has an inherent directivity. Therefore, when measuring power, it is sufficient with a scalar measurement technique as used in [9] rather than the vector corrected technique used in [7, 8]. Since power measurements are sensitive to imperfect directivity we investigate the directivity of the probe. We have also measured the frequency dependence of the coupling and its sensitivity to positioning errors.

A. Coupling

The coupling was measured with the same method as in [9] with an HP 8510C VNA using a two port test set, see Fig. 3. Before the measurements an unknown-thru [11] calibration was made in a 2.92 mm coaxial interface. The second port of the microstrip board and the second port of the loop-coupler were terminated with low reflective loads.

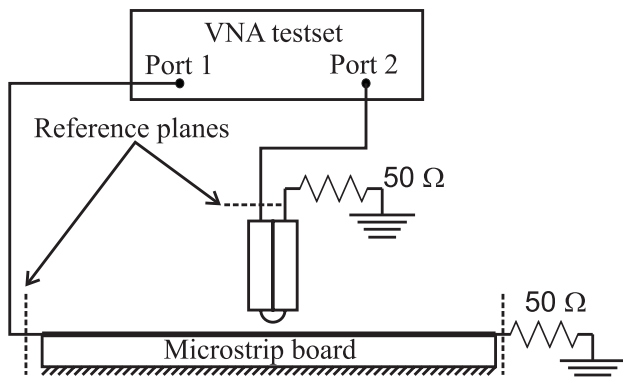

Fig. 3. Block-diagram of the setup used to measure probe coupling

Fig. 4 shows the measured coupling of the probes versus frequency and Fig. 5 and 6 show the coupling versus vertical position centered over the conductor for the two probes respectively. To limit the number of traces in the diagrams, results are shown for 10, 20, 30 and 40 GHz.

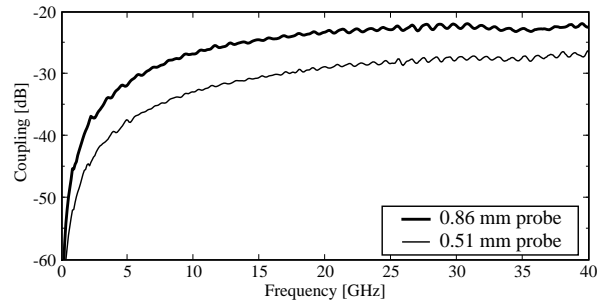

Fig. 4. Coupling vs frequency centered 250 μm above the conductor

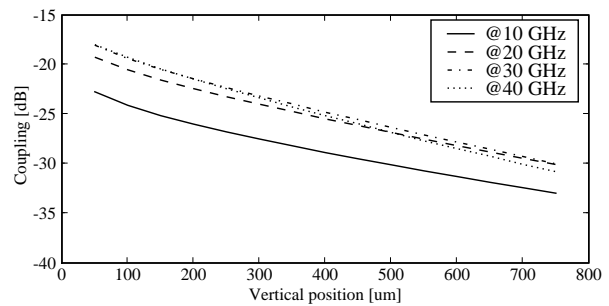

Fig. 5. Coupling vs vertical position centered over the conductor for the 0.86 mm probe

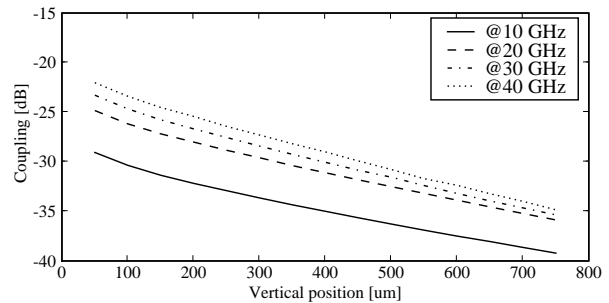

Fig. 6. Coupling vs vertical position centered over the conductor for the 0.51 mm probe

In the following diagrams we study the effect of transversal probe positioning on the coupling. When measuring a device under test (DUT) it is desirable not to disturb its operating conditions too much. It is also desirable to keep the uncertainty in the coupling due to a vertical positioning error low. Therefore this study was made with at a height of 250 μm over the substrate. At this height the coupling is less than -22 dB over the entire frequency range for both probes and the impact on the circuit board transmission and reflection is

negligible according to results in [9]. Figs. 7 and 8 show the coupling measured versus transversal position for both probes respectively. As can be seen the coupling is insensitive to transversal positioning errors when placed over the middle of the microstrip conductor.

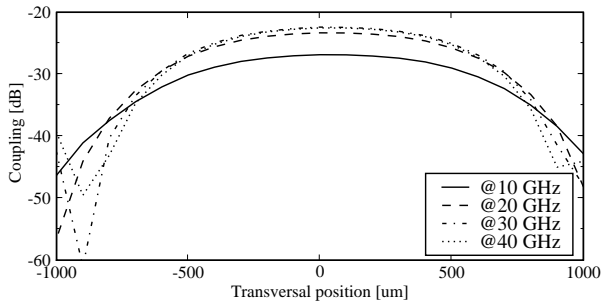

Fig. 7. Coupling vs transversal position at 250 μm height for the 0.86 mm probe

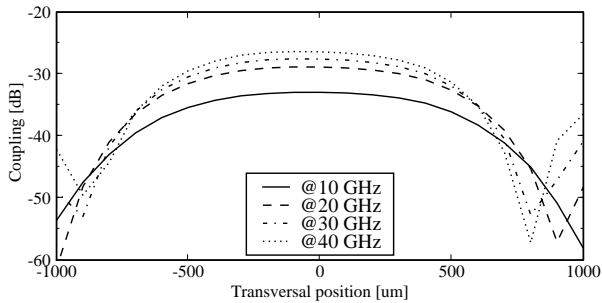

Fig. 8. Coupling vs transversal position at 250 μm height for the 0.51 mm probe

B. Directivity

The directivity was measured with the VNA HP 8510C and a direct access receiver testset connected as in Fig. 9.

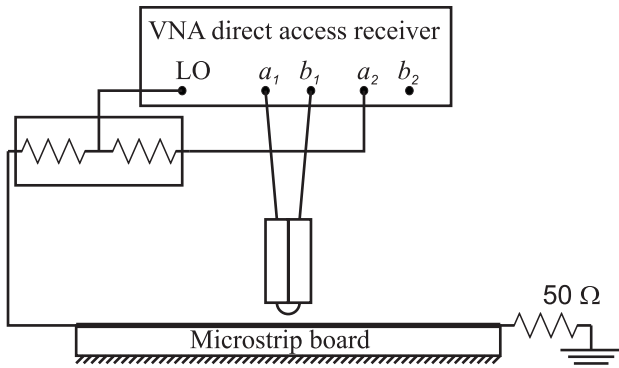

Fig. 9. Block-diagram of the setup used to measure probe directivity

The power splitter and the connection to the testset port a_2 were used to assure phase locking of the VNA even when the signals from the probe were weak. The directivity is calculated as b_1/a_1 . This is a reasonable method if the reflection as

seen into the 50 Ω load is low. In the test setup the planar transmission line is long which allows for time gating which further reduces the reflection from the 50 Ω load. Furthermore, the measurement requires a good balance between the a_1 and b_1 receivers. This was checked before measurement. Fig. 10 shows the directivity of the probes versus frequency. The decrease in the measured directivity at the low frequency end is probably due to the limited dynamic range in the VNA causing noise to enter the discrete Fourier transforms when the coupling is weak.

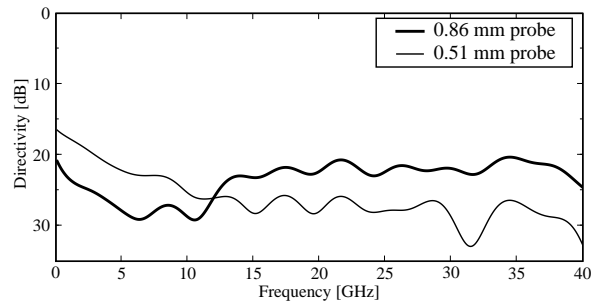

Fig. 10. Directivity vs frequency centered 250 μm above the conductor

Figs. 11 and 12 show the directivity versus vertical position centered over the conductor and Figs. 13 and 14 show the directivity measured versus transversal position at 250 μm height over the substrate. Similar to the coupling, the directivity is insensitive to transversal positioning errors when placed over the middle of the microstrip conductor.

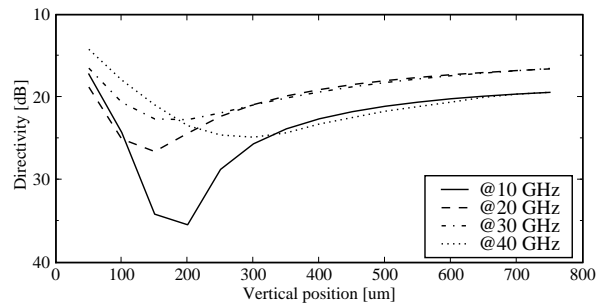

Fig. 11. Directivity vs vertical position for the 0.86 mm probe

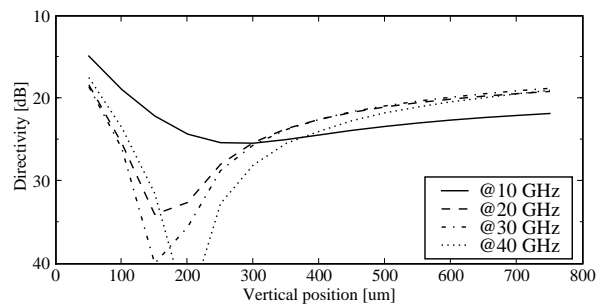

Fig. 12. Directivity vs vertical position for the 0.51 mm probe

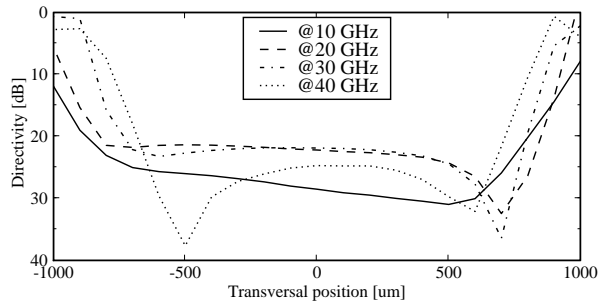

Fig. 13. Directivity vs transversal position for the 0.86 mm probe at 250 μm height

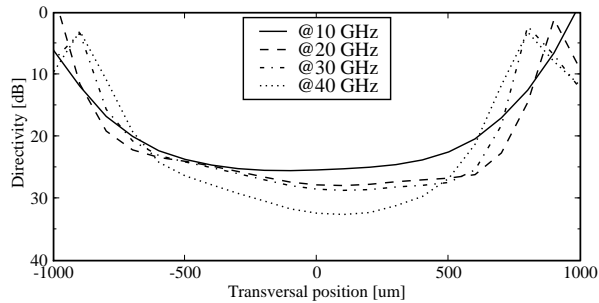

Fig. 14. Directivity vs transversal position for the 0.51 mm probe at 250 μm height

C. Uncertainty in power measurements

The uncertainty in the measurement of the power level of a forward wave depends on the sensitivity in the coupling to positioning errors, the directivity, and the magnitude of the reverse wave. The uncertainties due to a 5 μm repeatability of the vertical position and a 50 μm repeatability of the vertical position are shown versus frequency in Table I for the two probes.

TABLE I
COUPLING SENSITIVITIES FOR THE TWO PROBES AT 250 μm HEIGHT
CENTERED OVER THE CONDUCTOR

Frequency [GHz]	0.86 mm probe		0.51 mm probe	
	Vertical sensitivity [dB/5 μm]	Transverse sensitivity [dB/50 μm]	Vertical sensitivity [dB/5 μm]	Transverse sensitivity [dB/50 μm]
10	0.075	0.036	0.073	0.030
20	0.078	0.040	0.079	0.037
30	0.087	0.048	0.087	0.061
40	0.095	0.045	0.094	0.068

In scalar measurements, the uncertainty in the measured forward wave level caused by the directivity depends on the magnitude of the reverse wave which in its turn depends on the reflection coefficient as seen into the DUT (Γ_L). The directivity of the two probes is summarized in Table II.

TABLE II
DIRECTIVITY OF THE TWO PROBES AT 250 μm HEIGHT CENTERED OVER
THE CONDUCTOR

Frequency [GHz]	0.86 mm probe	0.51 mm probe
	Directivity [dB]	Directivity [dB]
10	28.7	25.3
20	22.3	28.0
30	21.9	28.7
40	24.6	32.7

By taking the worst case sensitivities to positioning errors and the worst case directivity for the two probes we can make a simple uncertainty budget, see Tables III and IV. In this case we only study the uncertainty contributions specific to the noncontacting technique.

TABLE III
UNCERTAINTY BUDGET FOR THE 0.86 MM PROBE

Uncertainty contribution	@ $\Gamma_L =$ -20 dB	@ $\Gamma_L =$ -15 dB	@ $\Gamma_L =$ -10 dB	@ $\Gamma_L =$ -5 dB
Vertical position $\pm 5 \mu\text{m}$	0,095 dB	0,095 dB	0,095 dB	0,095 dB
Transversal position $\pm 50 \mu\text{m}$	0,048 dB	0,048 dB	0,048 dB	0,048 dB
Directivity $\geq 22 \text{ dB}$	0,069 dB	0,124 dB	0,221 dB	0,397 dB
Summed uncertainty	0.13 dB	0.16 dB	0.25 dB	0.41 dB

TABLE IV
UNCERTAINTY BUDGET FOR THE 0.51 MM PROBE

Uncertainty contribution	@ $\Gamma_L =$ -20 dB	@ $\Gamma_L =$ -15 dB	@ $\Gamma_L =$ -10 dB	@ $\Gamma_L =$ -5 dB
Vertical position $\pm 5 \mu\text{m}$	0,094 dB	0,094 dB	0,094 dB	0,094 dB
Transversal position $\pm 50 \mu\text{m}$	0,068 dB	0,068 dB	0,068 dB	0,068 dB
Directivity $\geq 25 \text{ dB}$	0,049 dB	0,087 dB	0,156 dB	0,279 dB
Summed uncertainty	0,13 dB	0,15 dB	0,19 dB	0,30 dB

IV. REFLECTION COEFFICIENT

The inherent directivity of the probes is approximately 20 to 25 dB. This limits their usefulness for scalar measurement of reflection coefficient. Therefore it is preferable to use a VNA with a direct access receiver for this purpose. The measurement setup is shown in Fig. 15. Prior to measurement we make a short open load (SOL) calibration of the VNA in the microstrip environment. The calibration standards and the DUT were mounted on individual substrates at the reference plane indicated in Fig. 15. The short standard was made by soldering a copper foil to the ground plane, the open by leaving the microstrip end unconnected and the load by soldering two surface mount 100 Ω resistors in parallel to the ground plane. The DUT consists of two 50 Ω resistors soldered in parallel

to the ground plane. The probe was placed at a distance of 18 mm from the reference plane. Figs. 16 and 17 show the reflection coefficient of the DUT measured with the 0.86 and 0.51 mm probes respectively. Figs. 16 and 17 also show a verifying coaxial measurement. The coaxial measurement has been time gated to reduce the effects of repeatability in the coaxial to microstrip transition. From Figs. 16 and 17 we see that the 0.51 mm probe gives slightly better measurements above 30 GHz.

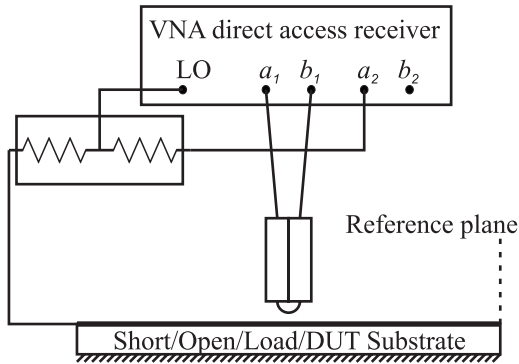

Fig. 15. Block-diagram of the setup used for measurement of reflection coefficient

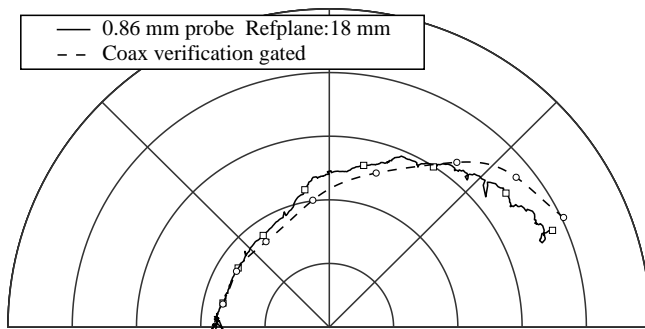

Fig. 16. Reflection coefficient measured from 0.1 to 40 GHz with the 0.85 mm probe and coaxially. Markers every 5 GHz.

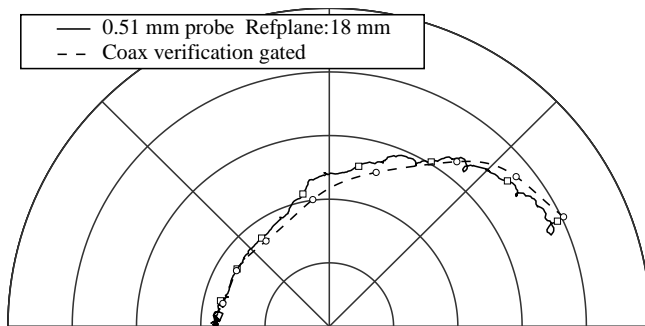

Fig. 17. Reflection coefficient measured from 0.1 to 40 GHz with the 0.51 mm probe and coaxially. Markers every 5 GHz.

V. DISCUSSION

Besides the properties investigated in this paper, the interaction of the probe with the circuit is important. This was investigated in [9] and was found to be acceptable.

Although the 0.51 mm probe has better directivity this may not be the case in a real application depending on the mismatch of the connecting instruments. One way to handle such a problem is to change to the use of two single ended loop-couplers (with the second arm terminated in a 50Ω load). This would also make it meaningful to further tune the directivity of the probes. The directivity of the probe is dependent on the balance between capacitive and inductive coupling. This balance can be tuned by varying the geometry of the loop-coupler [10]. If this is successful, scalar noncontacting measurement of reflection coefficient would be feasible.

VI. CONCLUSION

We have demonstrated noncontacting measurement of power and reflection coefficient up to 40 GHz. In both cases we believe the uncertainties of the noncontacting technique are acceptable.

ACKNOWLEDGMENT

The authors thank the Swedish metrology council and VINNOVA Swedish Agency for Innovation Systems for financial support. We also thank Ericsson AB for their cooperation and encouraging discussions.

REFERENCES

- [1] G. David, W. Schroeder, D. Jäger, and I. Wolff, "2D electro-optic probing combined with field theory based multimode wave amplitude extraction: a new approach to on-wafer measurement," in *IEEE International Microwave Symposium Digest*, 1995.
- [2] G. Yingjie and I. Wolff, "A miniature magnetic field probe for measuring fields in planar high-frequency circuits," in *IEEE International Microwave Symposium Digest*, 1995.
- [3] G. Yingjie and I. Wolff, "A new miniature magnetic field probe for measuring three-dimensional fields in planar high-frequency circuits," *IEEE Transactions on Microwave Theory and Techniques*, vol. 44, no. 6, pp. 911–18, 1996.
- [4] G. Yingjie and I. Wolff, "Measurements of field distributions and scattering parameters in multiconductor structures using an electric field probe," in *IEEE International Microwave Symposium Digest*, 1997.
- [5] S. S. Osofsky and S. E. Schwarz, "A non-contacting probe for measurements on high-frequency planar circuits," in *IEEE International Microwave Symposium Digest*, 1989.
- [6] S. S. Osofsky and S. E. Schwarz, "Design and performance of a non-contacting probe for measurements on high-frequency planar circuits," *IEEE Transactions on Microwave Theory and Techniques*, vol. 40, no. 8, pp. 1701–8, 1992.
- [7] J. Stenarson, K. Yhland, and C. Wingqvist, "An in-circuit, non-contacting, S-parameter measurement method," in *Proceedings of 57th ARFTG Conference*, (Phoenix, AZ), 2001.
- [8] J. Stenarson, K. Yhland, and C. Wingqvist, "An in-circuit, non-contacting, measurement method for S-parameters and power in planar circuits," *IEEE Transactions on Microwave Theory and Techniques*, vol. 49, no. 12, pp. 2567–2572, 2001.
- [9] K. Yhland and J. Stenarson, "Noncontacting measurement of power in microstrip circuits," in *ARFTG*, (San Francisco), pp. 201–205, ARFTG, 2006.
- [10] H. Early, "A wide-band directional coupler for wave guide," *Proceedings of the I.R.E. and Waves and Electrons*, no. Nov, pp. 883–886, 1946.
- [11] A. Ferrero and U. Pisani, "Two-port network analyzer calibration using an unknown "thru"," *Microwave and Guided Wave Letters*, pp. 505–507, 1992.